

5308341COM 2 Door Wide Cabinet

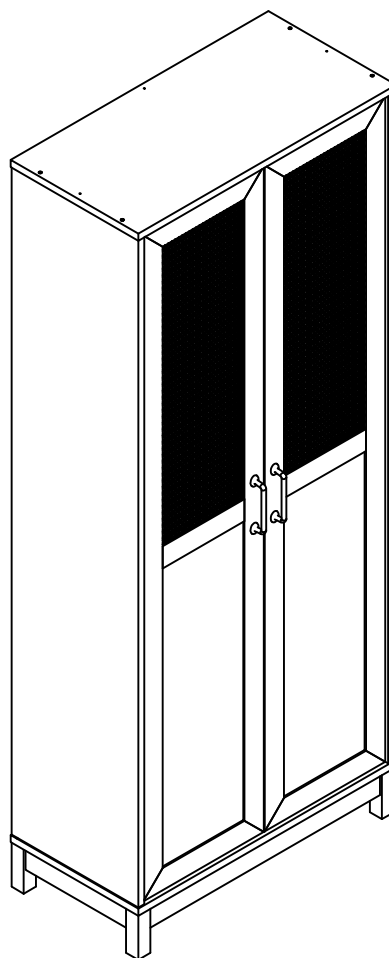

Date of Purchase ___ / ___ / ___
Lot Number:

B345308341COM0



Do Not Return This Product!
Contact our customer service team for help first.
Call: 1-800-489-3351 (toll free)
Visit: www.ameriwoodhome.com

THIS INSTRUCTION BOOKLET CONTAINS **IMPORTANT** SAFETY INFORMATION. PLEASE READ AND KEEP FOR FUTURE REFERENCE.

Secure Your Furniture

Keep your home and family safe with the wall anchor kit that is included with the product.

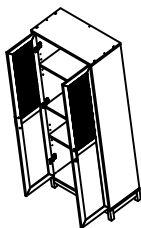

Serious or fatal crushing injuries can occur from tipping furniture.

WARNING: Manufacturer assumes no liability for improper installation or excessive loads placed on screws or bracket. This wall anchor is not a substitute for proper adult supervision.

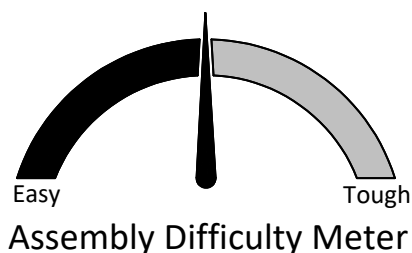

Follow Ameriwood Home



Contact Us!

Do NOT return this product!

Contact our friendly customer service team first for help.

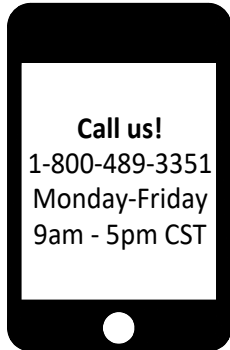

Visit ameriwoodhome.com to view the limited warranty valid in the U.S. and Canada.

Assembly Tips



Helpful Hints

PEOPLE NEEDED FOR ASSEMBLY: 1-2

- Open your item in the area you plan to keep it to avoid excessive heavy lifting.
- Identify, sort and count the parts before attempting assembly.
- Compression dowels are lightly tapped in with a hammer.
- Slides are labeled with a **R** (right) and **L** (left) for proper placement.
- Make sure to always face the point on the top of the Cam Lock towards the outer edge.
- Use all the nails provided for the back panel and spread them out equally.
- Back panel must be used to make sure your unit is sturdy.
- Do NOT use harsh chemicals or abrasive cleaners on this item.
- Never push, pull, or drag your furniture.

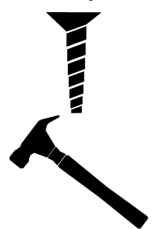

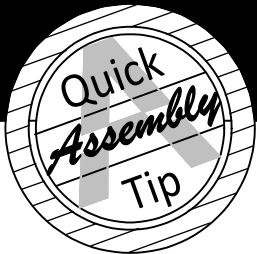

Before You Start

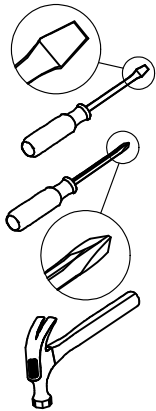

- ✓ Read through each step carefully and follow the proper order
- ✓ Separate and count all your parts and hardware
Parts are labeled on the surface or edge of the part
- ✓ Give yourself enough room for the assembly process
- ✓ Have the following tools: Flat Head Screwdriver, #2 Phillips Head Screwdriver and Hammer
- ✓ Caution: If using a power drill or power screwdriver for screwing, please be aware to slow down and stop when screw is tight. Failure to do so may result in stripping the screw.

Cam Lock Fastening System

This Cam Lock Fastening System will be used throughout the assembly process.

1

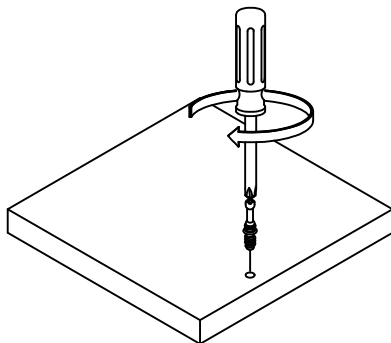

Screw CAM BOLT into hole.

2

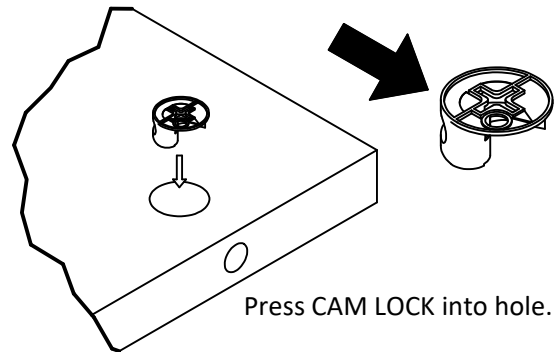

Press CAM LOCK into hole.

3

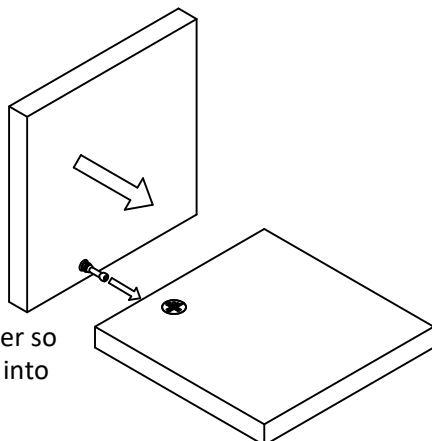

Press parts together so CAM BOLT inserts into edge hole.

4

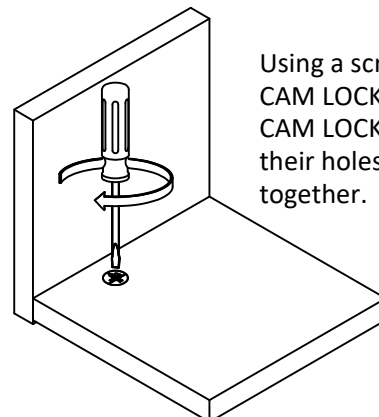

Using a screwdriver, turn the CAM LOCK clockwise to lock the CAM LOCK and CAM BOLT into their holes and fastening parts together.

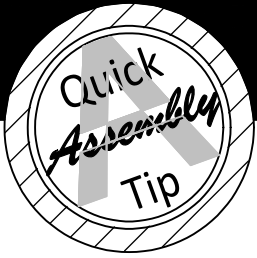

Before You Start

Please Note:

You may need to lightly tap the wood dowels into the holes during your assembly process.

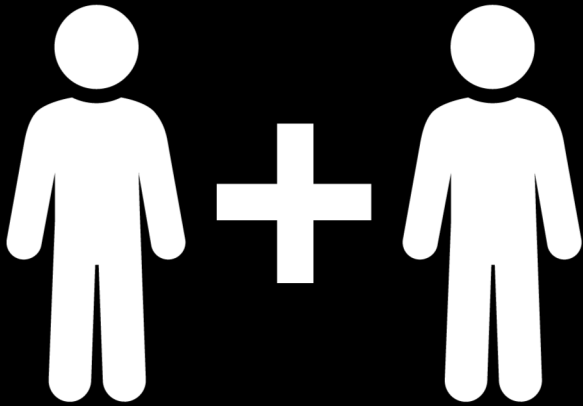
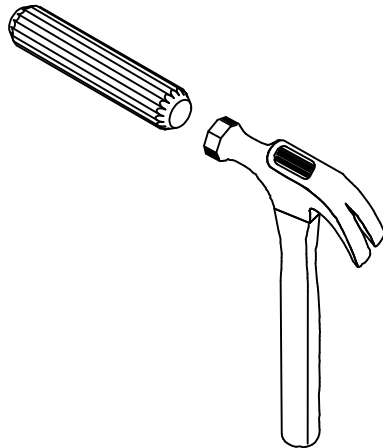

2 PEOPLE NEEDED FOR ASSEMBLY

**2 PERSONAS NECESITADAS
PARA LA ASAMBLEA**

**2 PERSONNES NÉCESSAIRES
POUR L'ASSEMBLAGE**

CAUTION: Failure to use 2 people for assembly could result in unit damage or personal injury.

PRECAUCIÓN: Si no se utilizan 2 personas para el ensamblaje, se pueden producir daños en la unidad o lesiones personales.

ATTENTION: Échec d'utiliser 2 personnes pour l'assemblage peut causer du dommage au meuble ou causer des blessures.

Board Identification

Not actual size

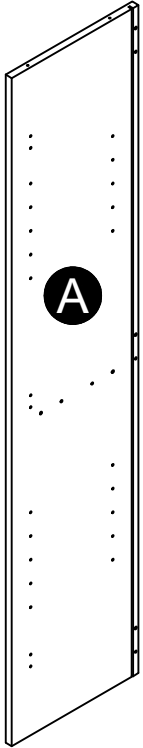

Left Panel
35308341010

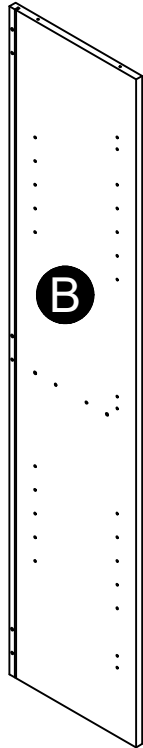

Right Panel
35308341020

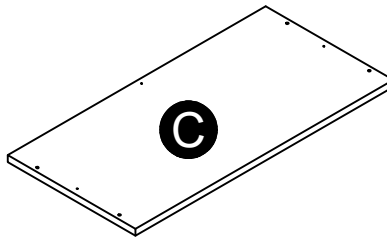

Top
35308341030

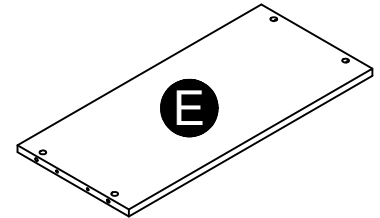

Shelf
35308341050

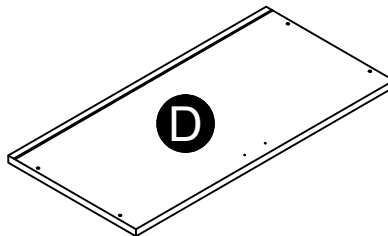

Bottom
35308341040

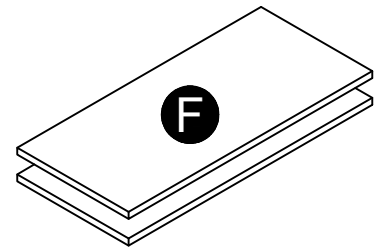

Adjustable Shelf (x2)
35308341060



Leg (x4)
35308341070

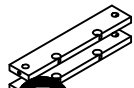

Side Rail (x2)
35308341090

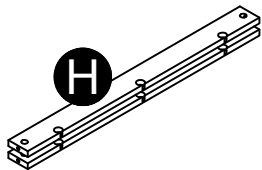

Lower Rail (x2)
35308341080

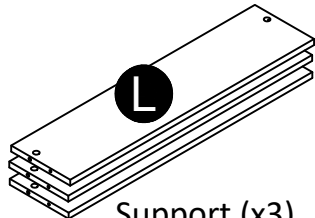

Support (x3)
35308000120

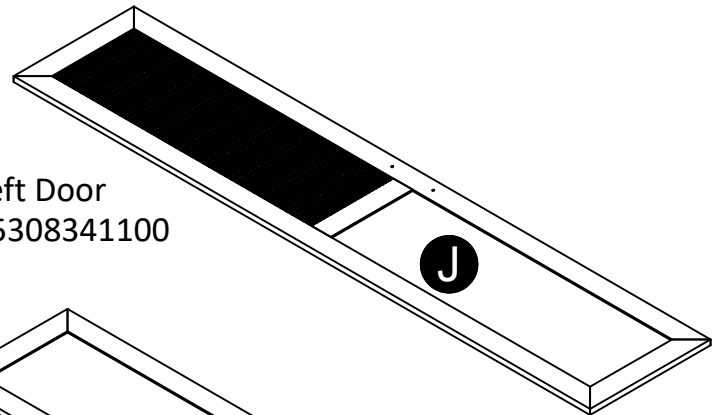

Left Door
35308341100

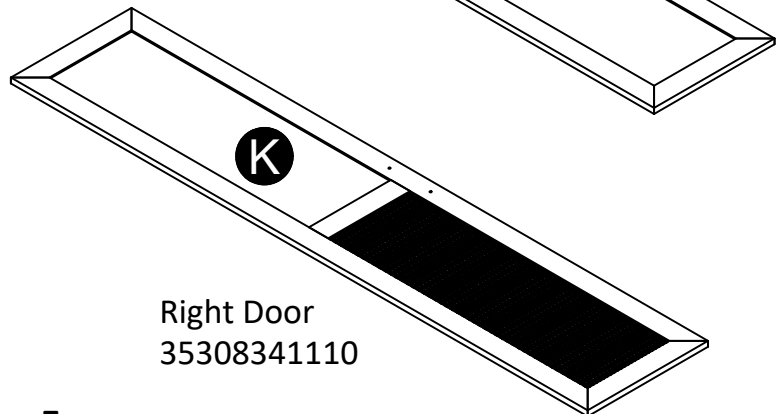

Right Door
35308341110

Board Identification

Not actual size

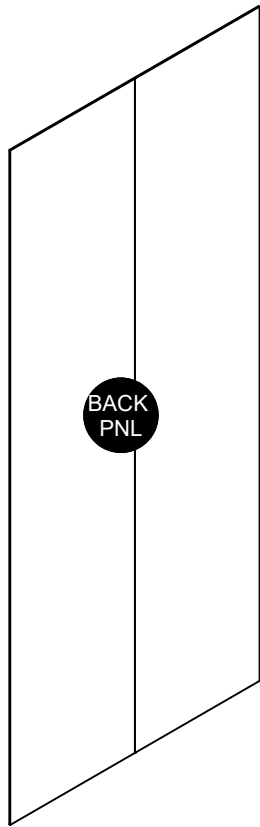

Back Panel
K530834100

This piece is paperboard construction. It is not made from wood, but is required for the assembly of your unit.

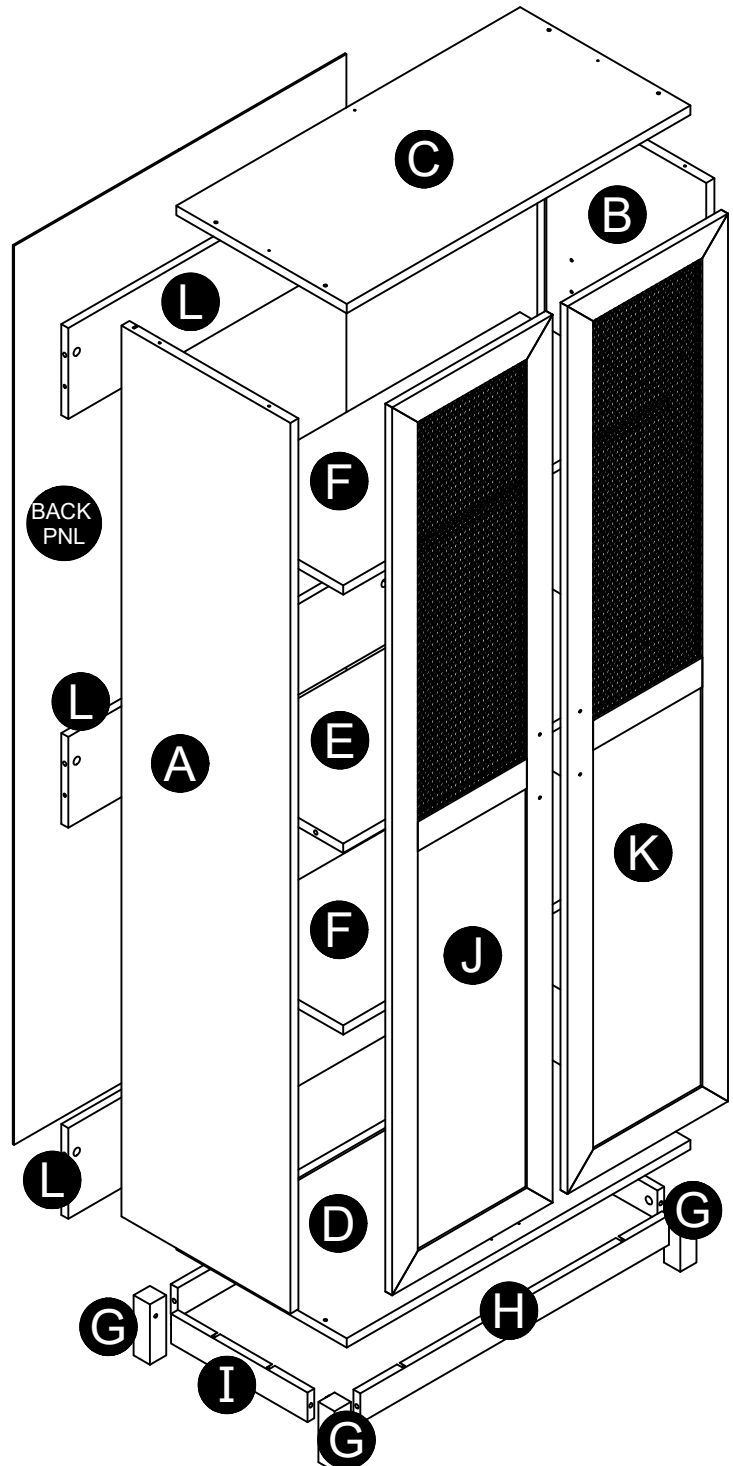

Part List

Actual Size



(x18)
#A22620
cam lock

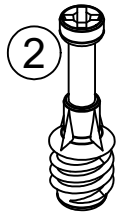

(x18)
#A22610
cam bolt



(x10)
#A21670
wood dowel

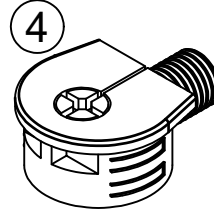

(x14)
#A22770
quickloc

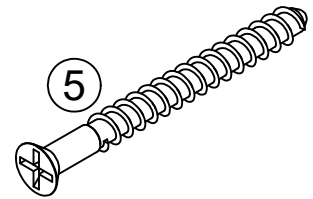

(x8)
#A23030
confirmat

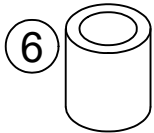

(x4)
#A89020
stop pin

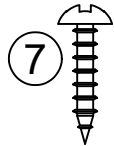

(x4)
#A11170
5/8" screw

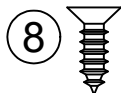

(x2)
#A11080
7/16" screw

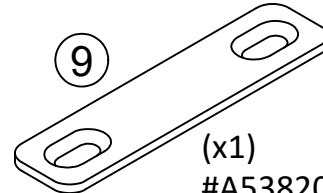

(x1)
#A53820
bracket

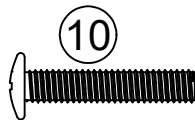

(x4)
#A17400
bolt



(x8)
#A80250
shelf support

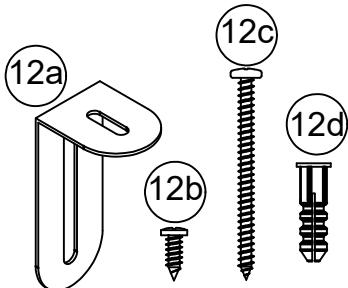

(x1)
#A84050
safety bracket

Not Actual Size

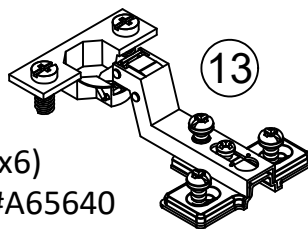

(x6)
#A65640
hinge

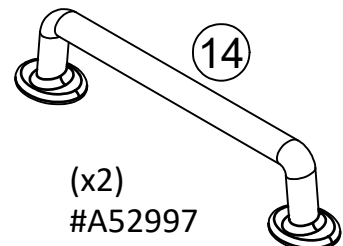

(x2)
#A52997
handle

STEP 1

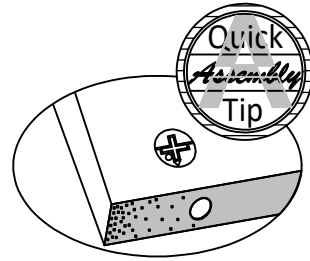
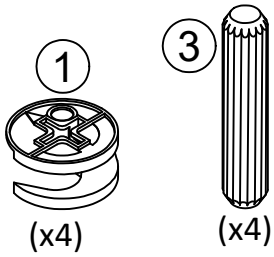

Proper orientation of CAM LOCK

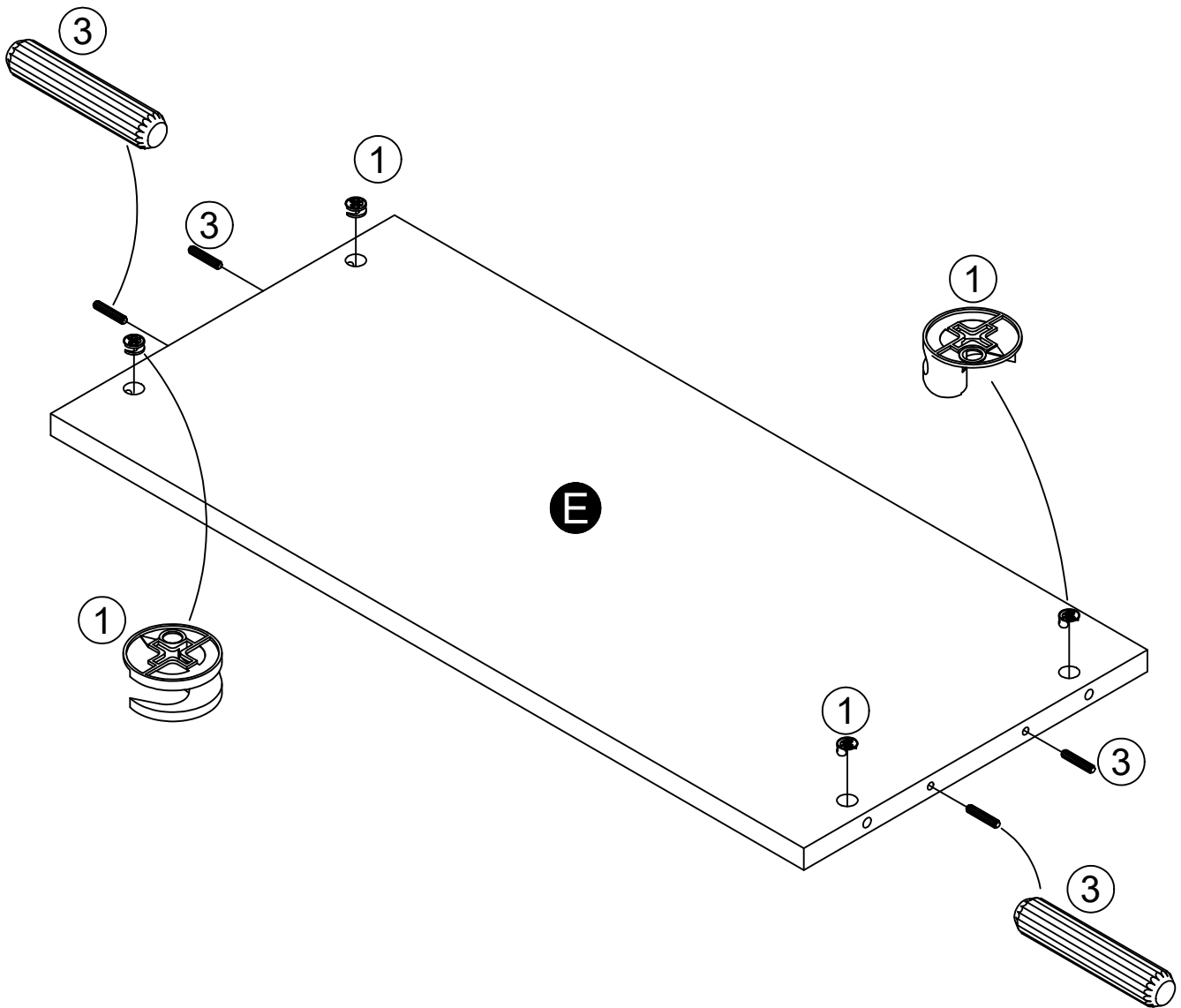

STEP 2

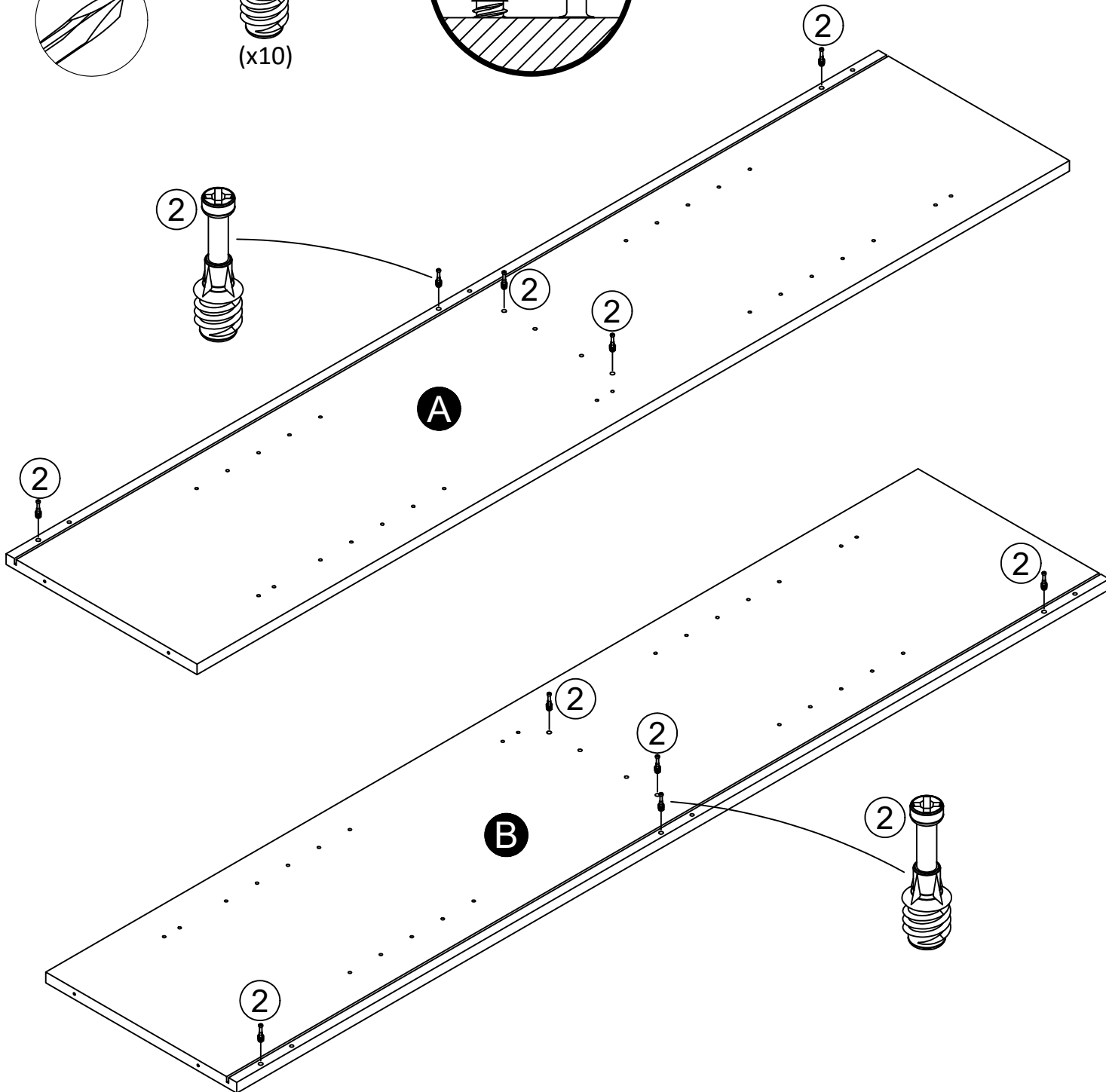
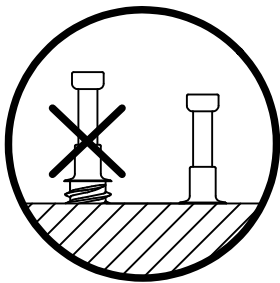
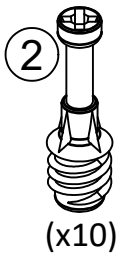
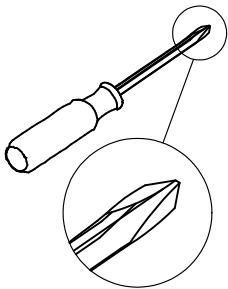

STEP 3

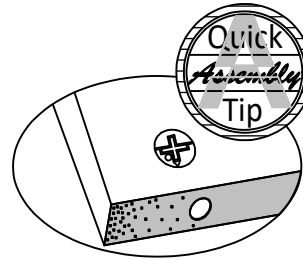
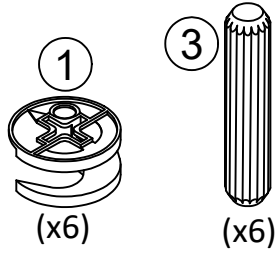

Proper orientation of CAM LOCK

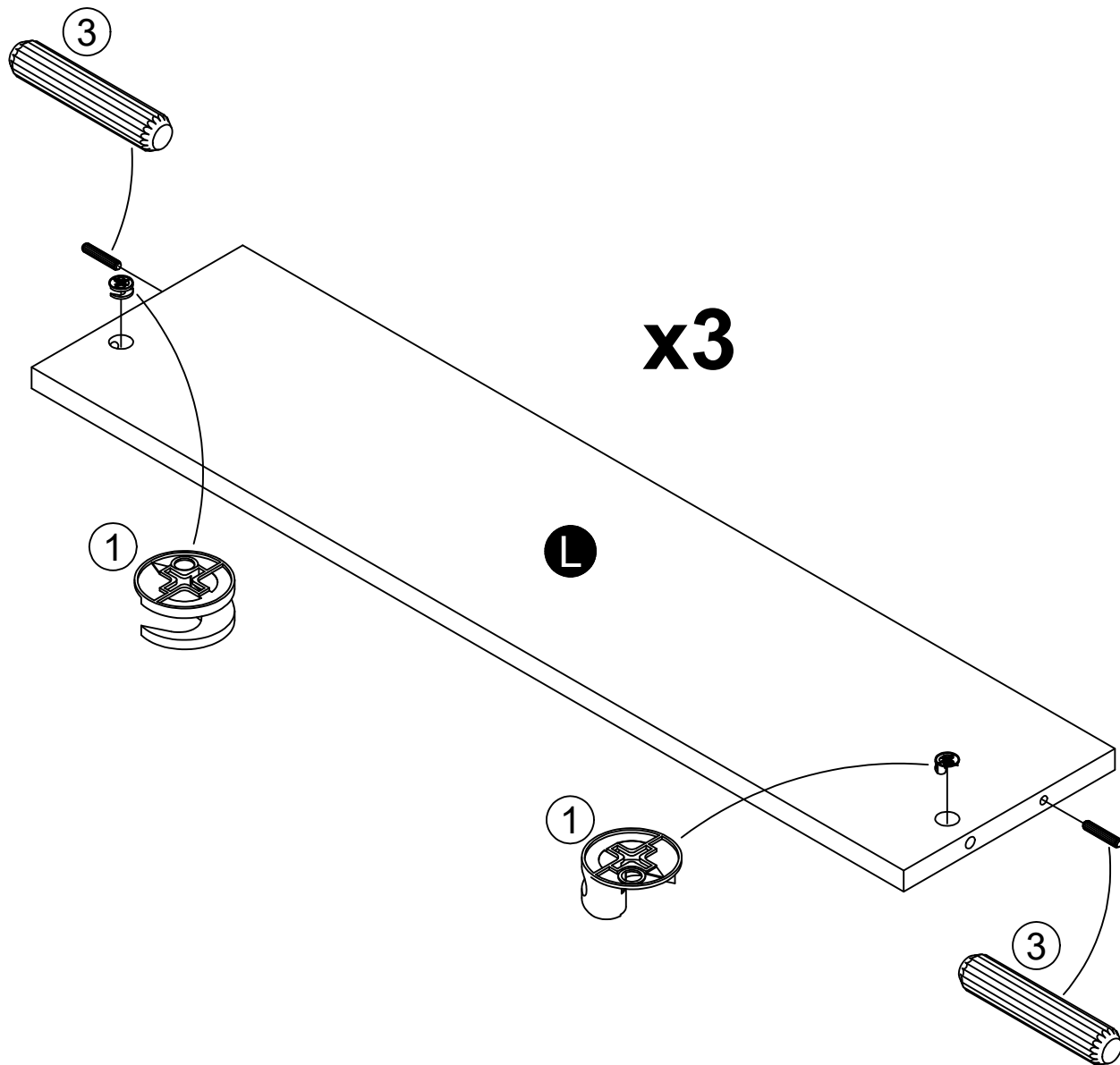

STEP 4

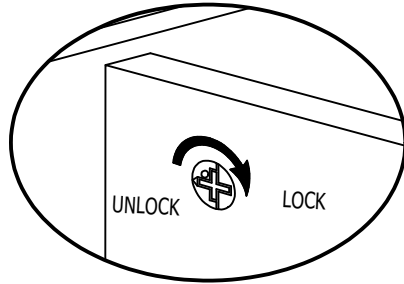
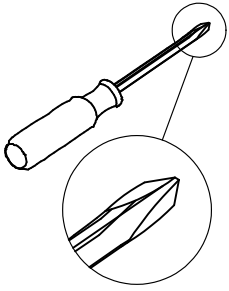

finished edges face up

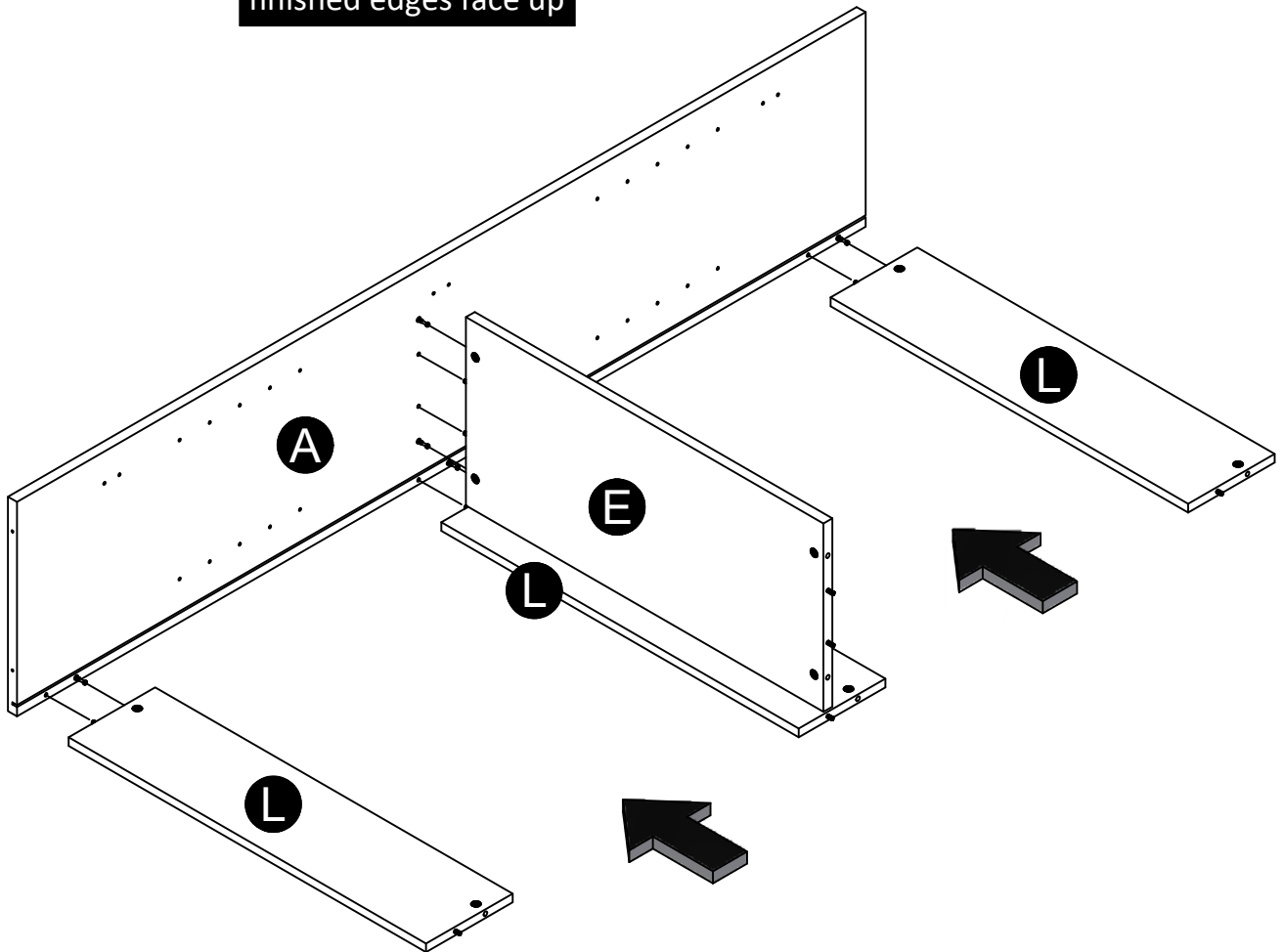

STEP 5

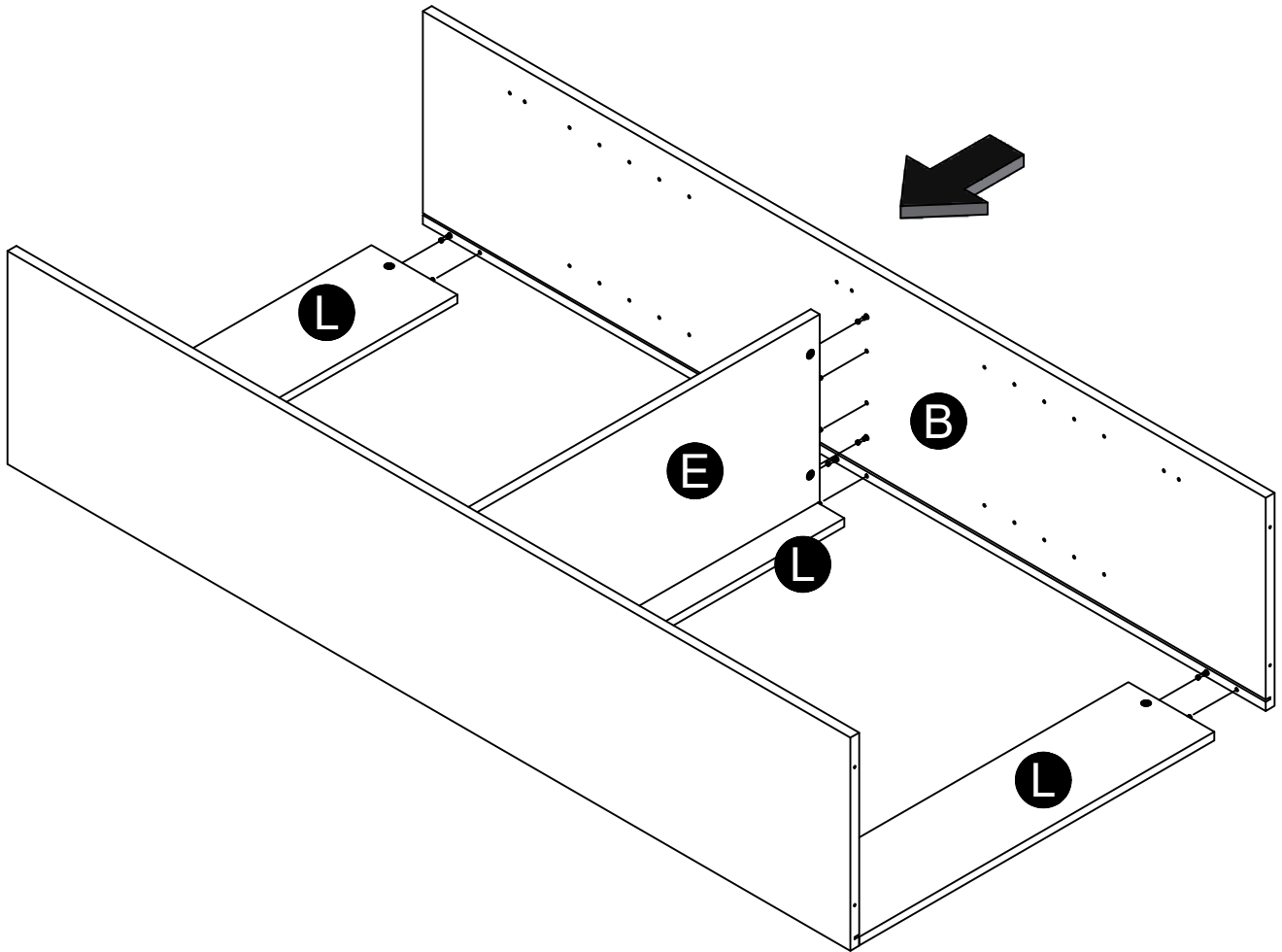
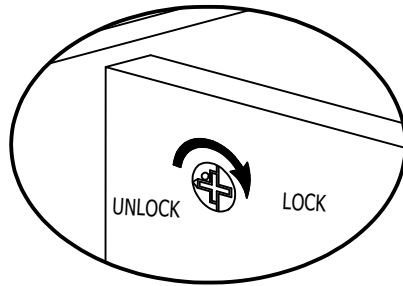
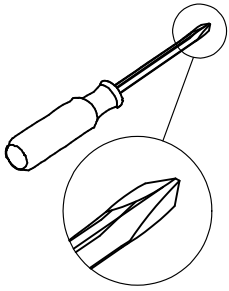

STEP 6

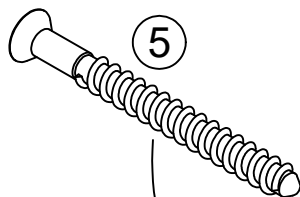
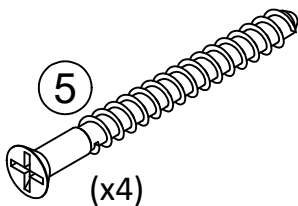
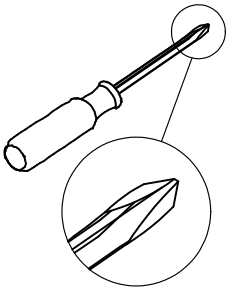

finished edges face up

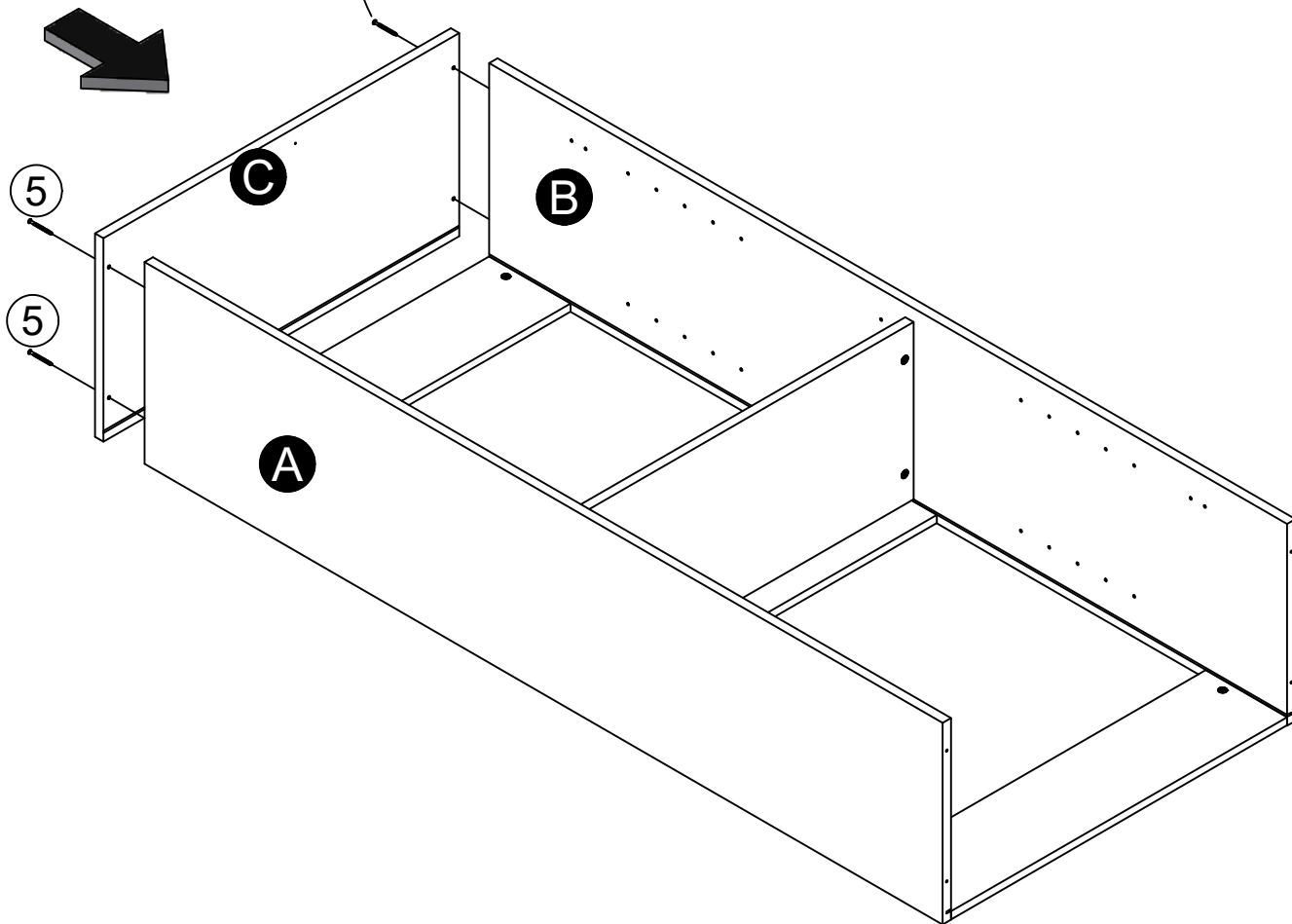

STEP 7

IMPORTANT! THE BACK PANEL IS A STRUCTURAL PART OF THIS UNIT AND MUST BE INSTALLED PROPERLY.

Unfold the back panel. With the finished surface facing up, slide the back panel into the groove in the left and right panels (A&B) seating into the groove in the top (C). Note, the back panel will be over the supports.

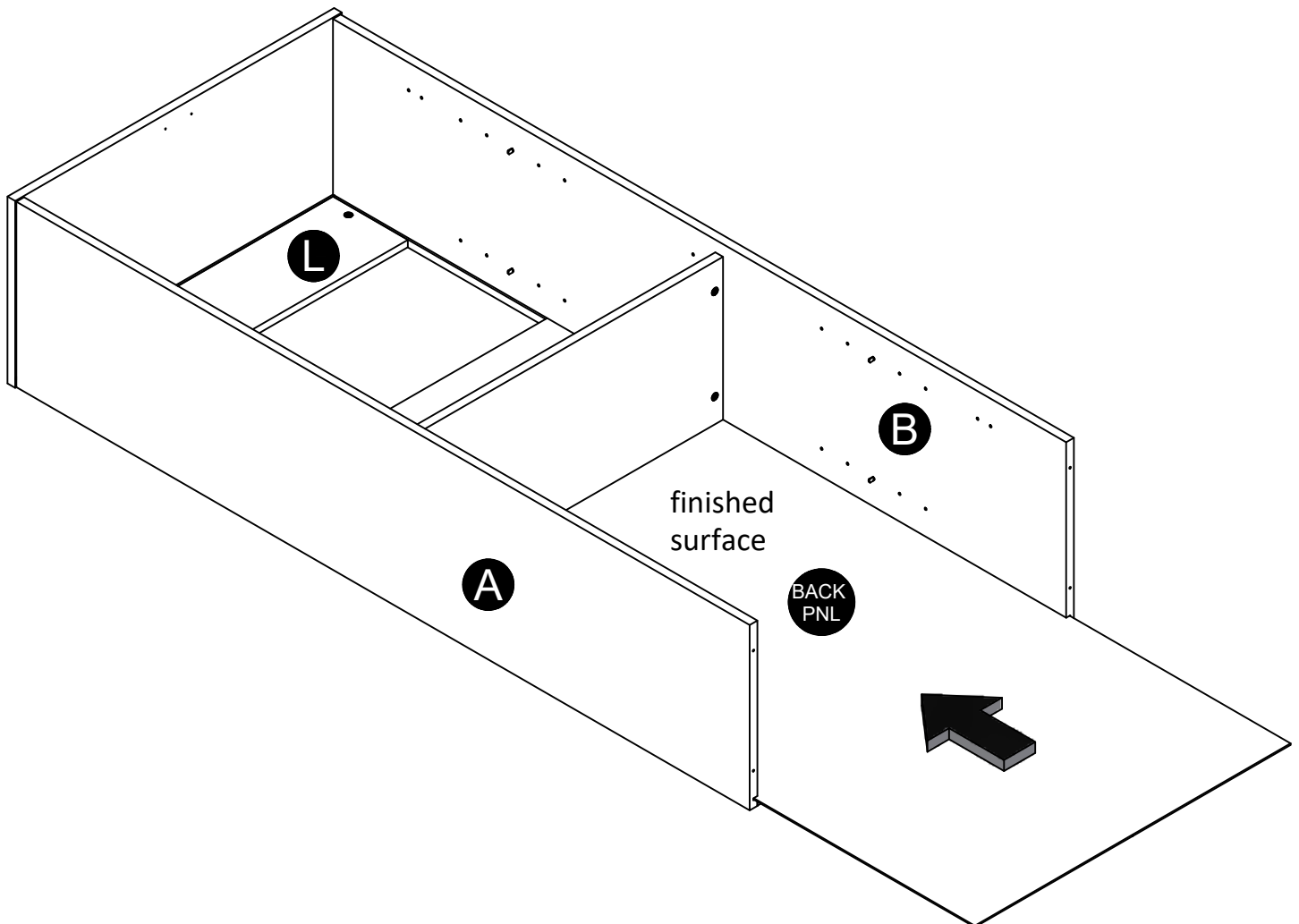

STEP 8

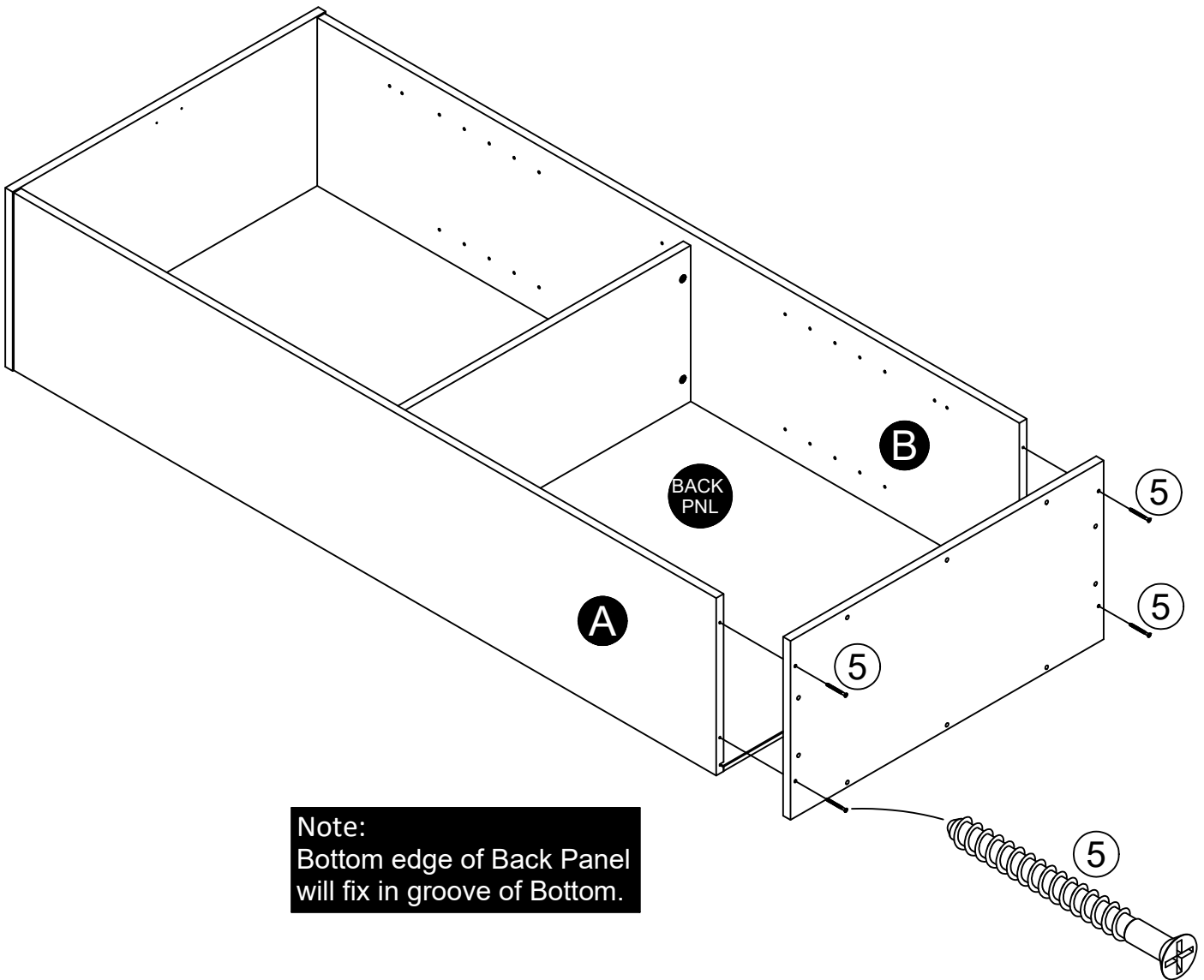
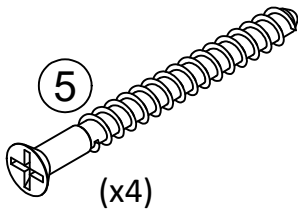
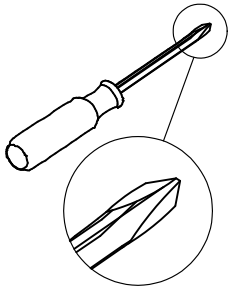

Note:
Bottom edge of Back Panel
will fix in groove of Bottom.

STEP 10

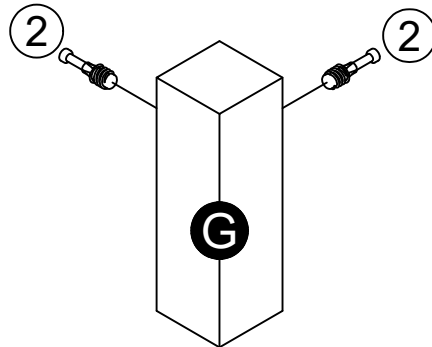
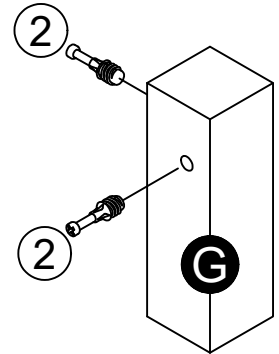
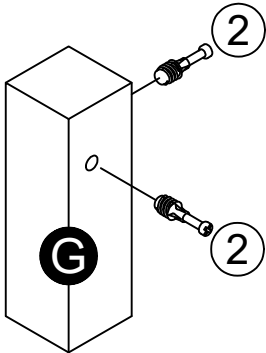
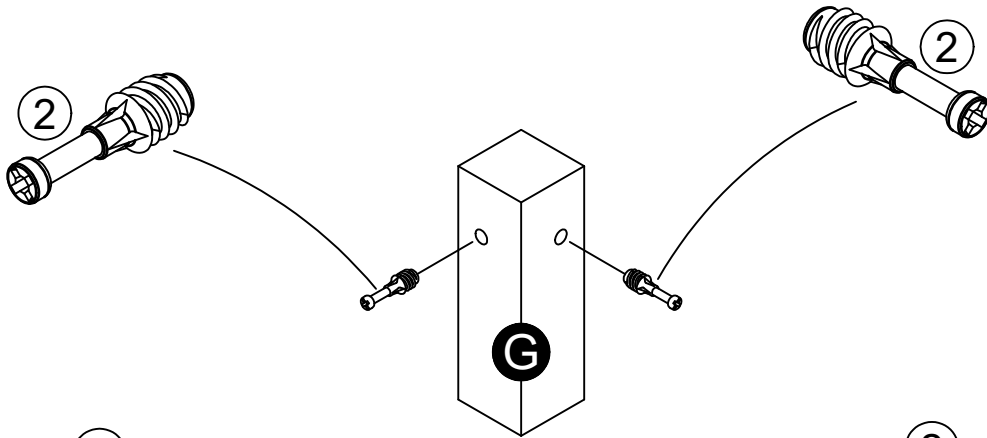
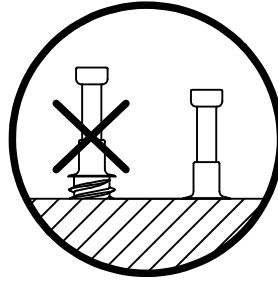
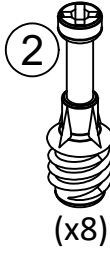
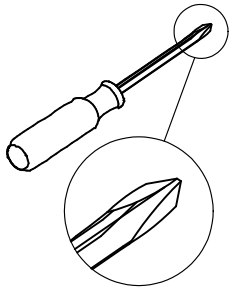

STEP 11

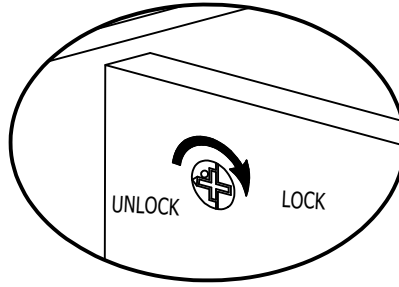
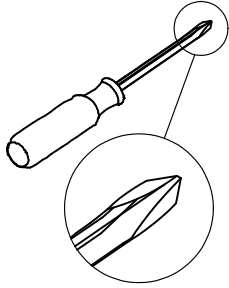

Top edges of both parts will be flush.

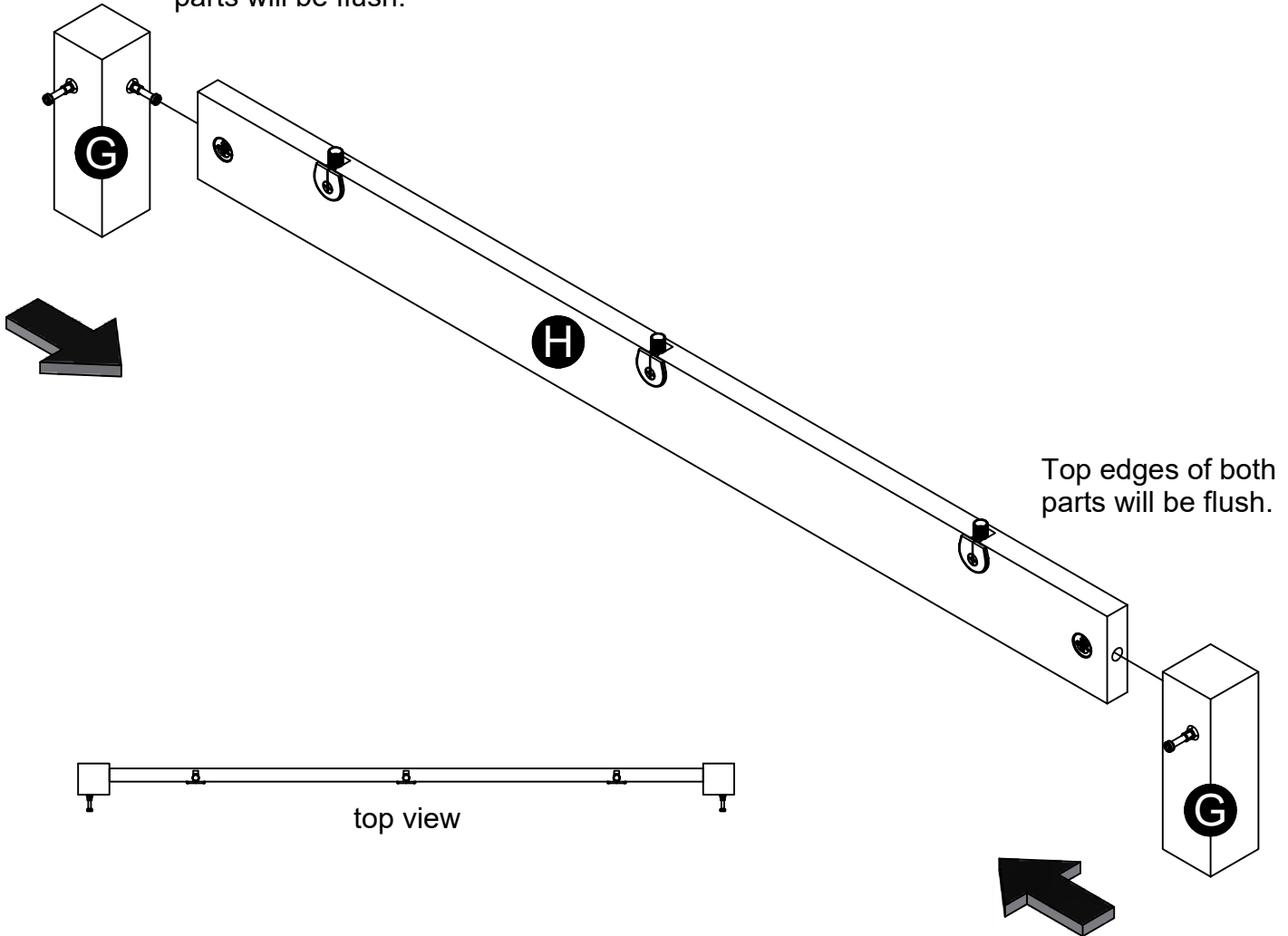

STEP 12

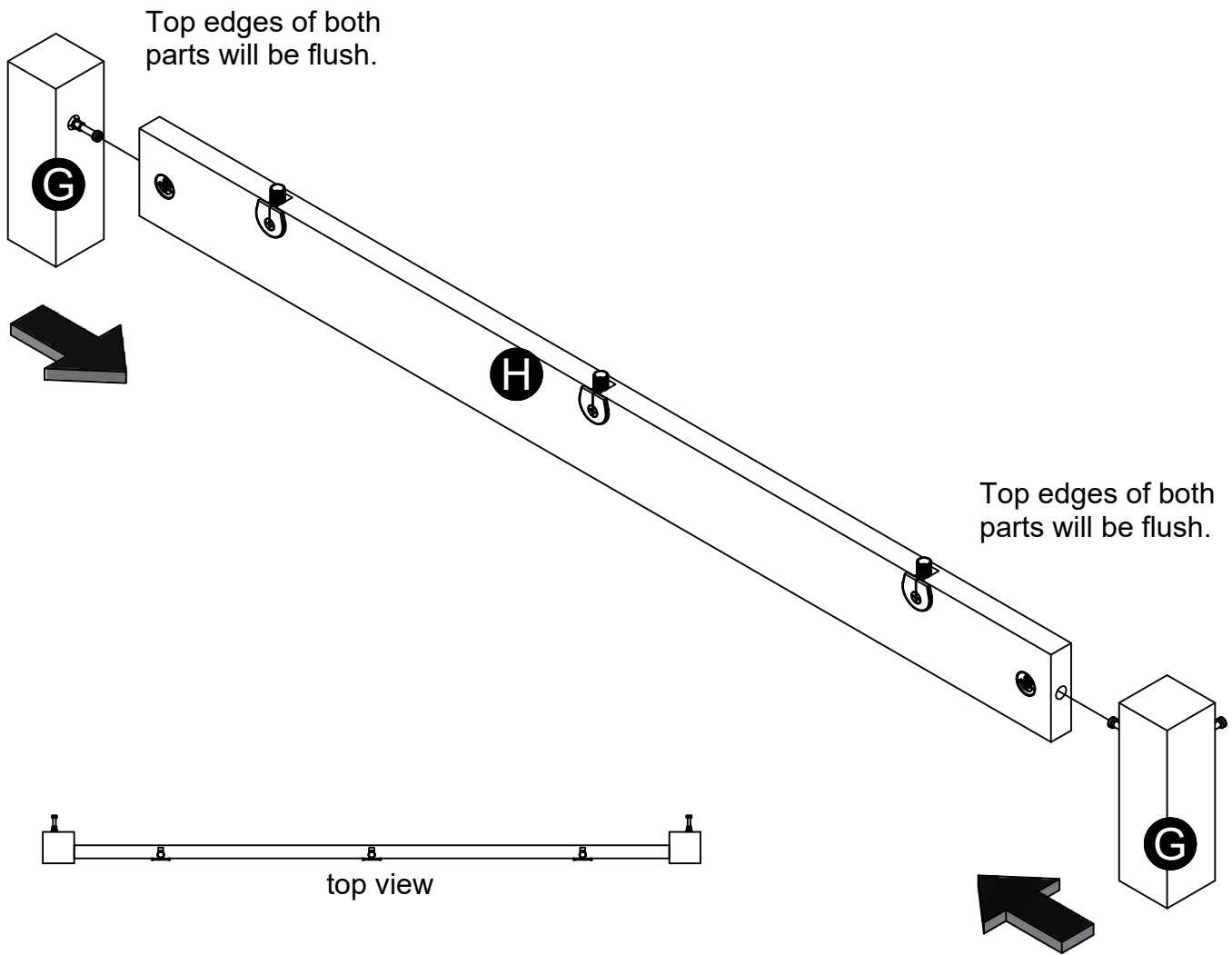
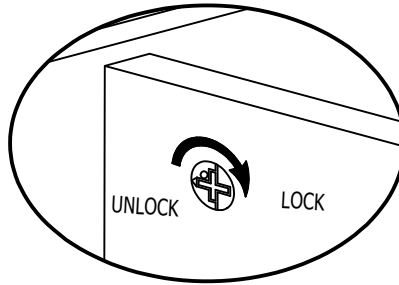
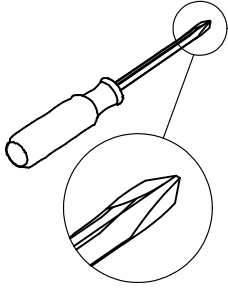

STEP 13

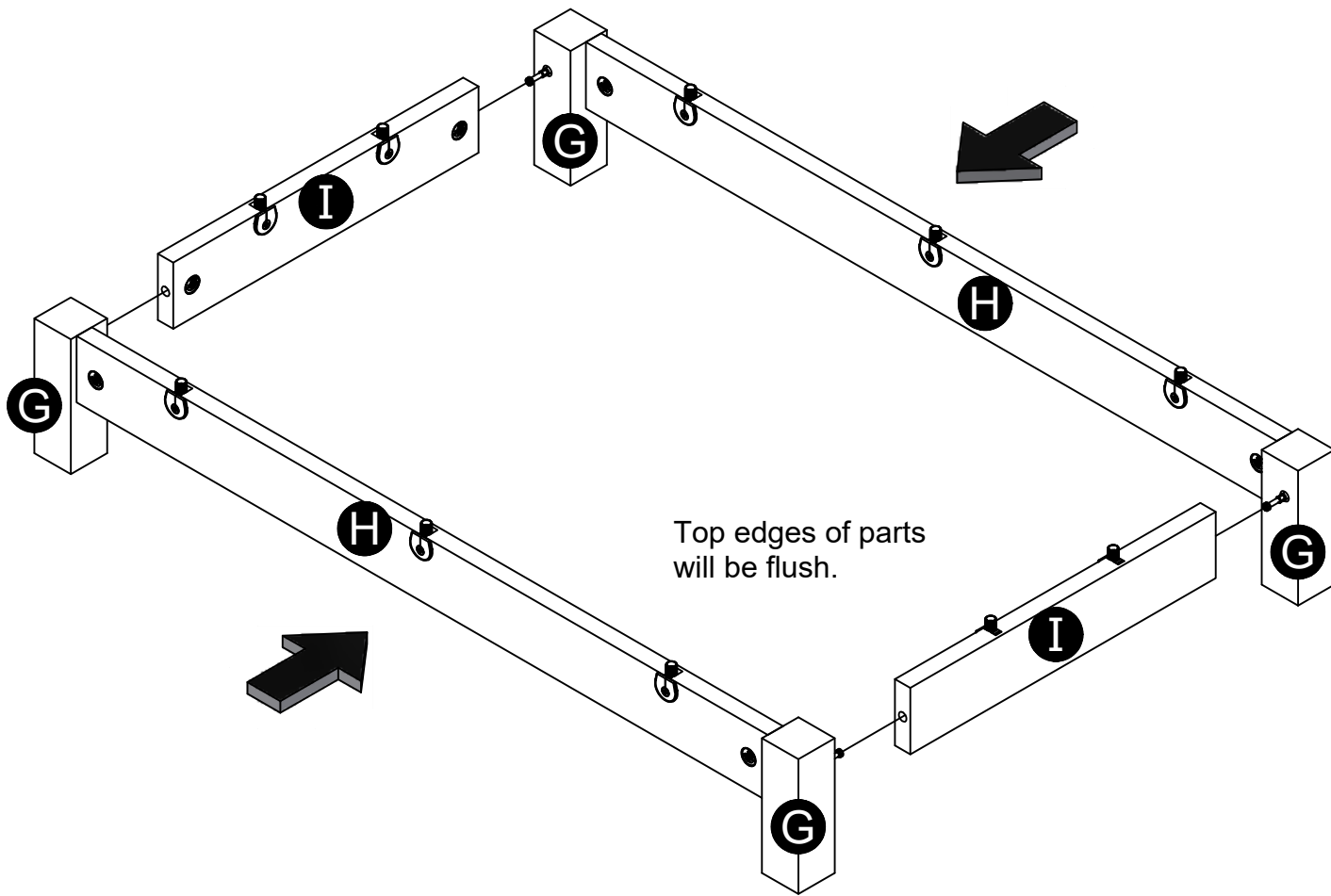
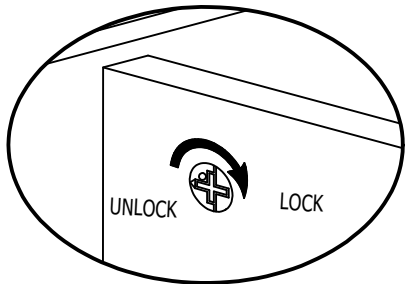
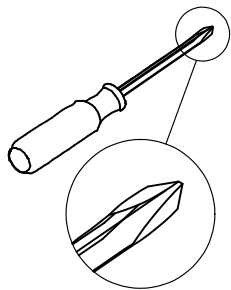

STEP 14

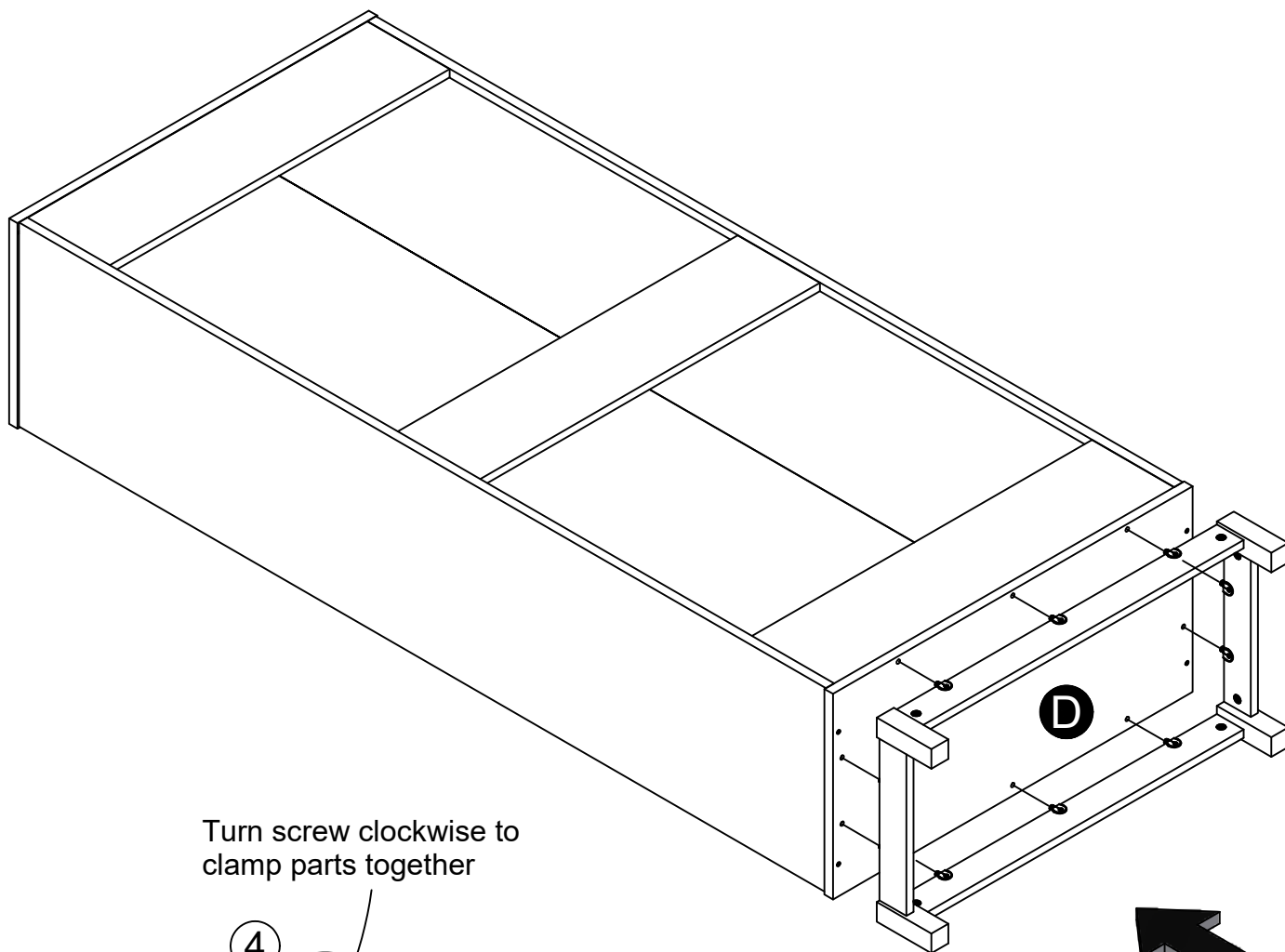

Turn screw clockwise to clamp parts together

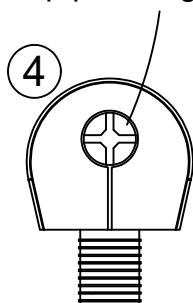

STEP 15

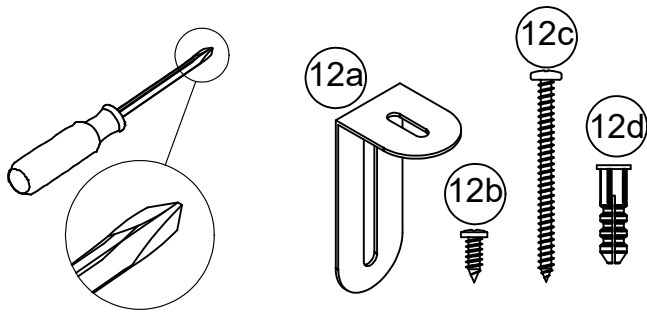

For Masonry, Concrete, or other wall materials:

Consult your local hardware store for appropriate anchors to securely attach the safety bracket.

IMPORTANT: THIS UNIT MUST BE SECURE TO THE WALL TO HELP PREVENT TIPOVER. FOLLOW THESE INSTRUCTIONS TO INSTALL THE ANTI-TIPPING SAFETY BRACKET PROVIDED WITH THIS PRODUCT.

WARNING

Serious or fatal crushing injuries can occur from furniture tipover.

To prevent tipover:

- * Install tipover restraint provided
- * Place heaviest items in the lowest drawers
- * Unless specifically designed to accommodate, do not set TVs or other heavy objects on the top of this product
- * Never allow children to climb or hang on drawers, door, or shelves
- * Never open more than one drawer at a time

Use of tipover restraints may only reduce, but not eliminate the risk of tipover

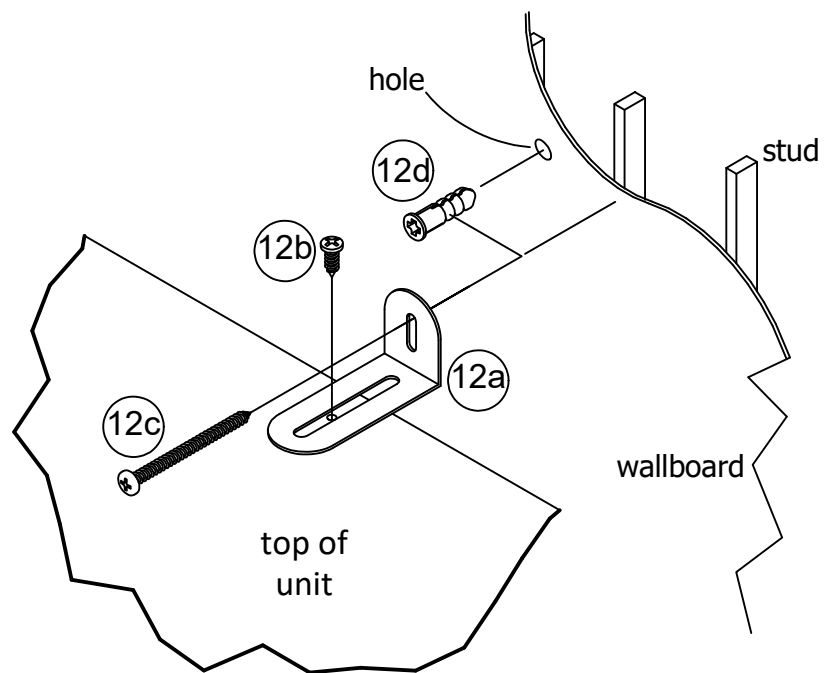

OPTION 1: Attachment into a wall stud (preferred method)

Using a stud finder, locate a stud in the wall. Place your unit against the wall, with the safety bracket aligned in this location. To make driving the screw easier, you can drill a 1/8" diameter pilot hole (3mm) through the safety bracket into the stud. Drive the screw through the safety bracket into the wall stud.

OPTION 2: Attachment into drywall

Locate your unit where desired against a wall and mark the wall through the safety bracket, then move your unit aside. Drill a 3/16" diameter hole (5mm) into the wallboard. Tap the wall anchor into the hole until it is flush. Move your unit into location and fasten the wall bracket to the wall anchor with the screw.

STEP 16

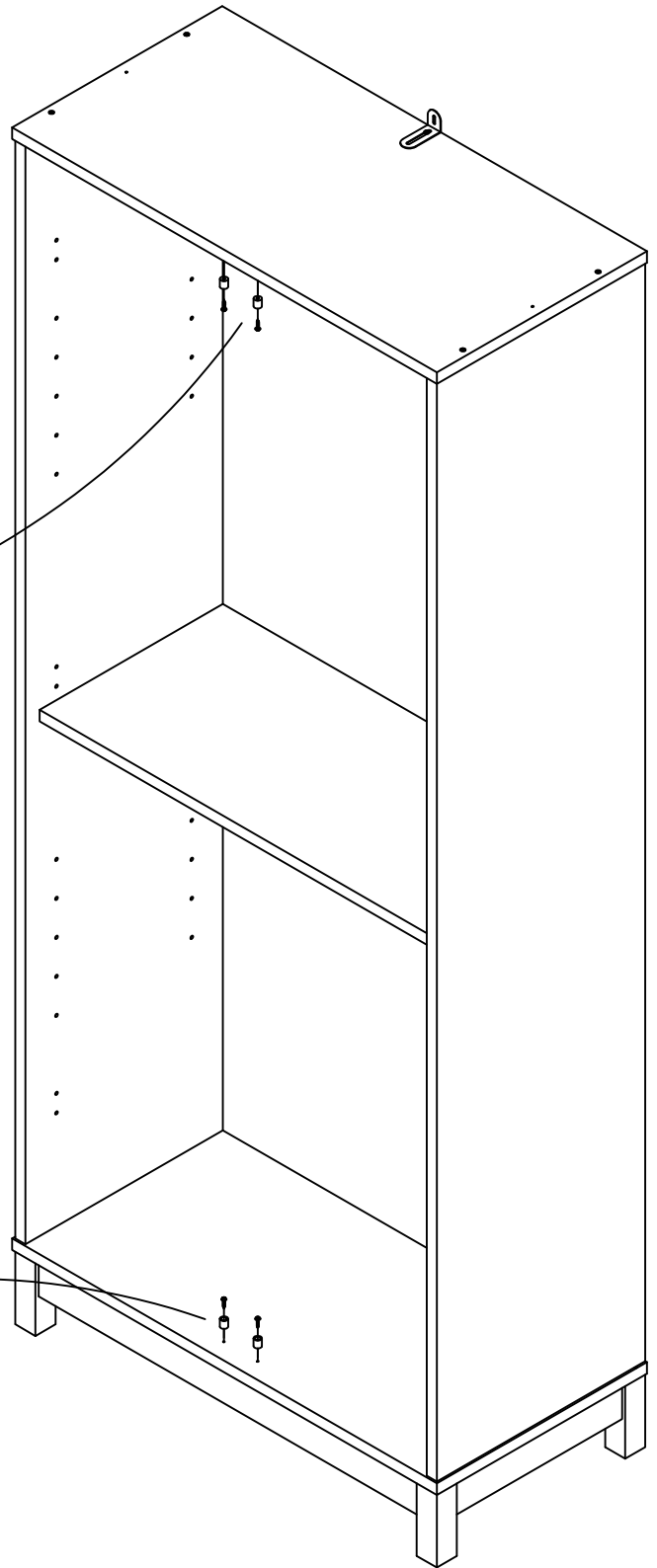
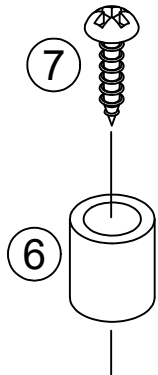
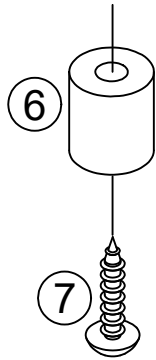
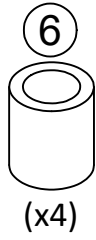
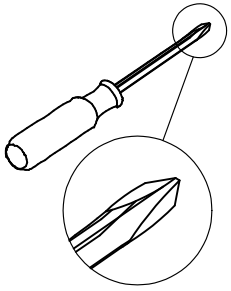

STEP 17

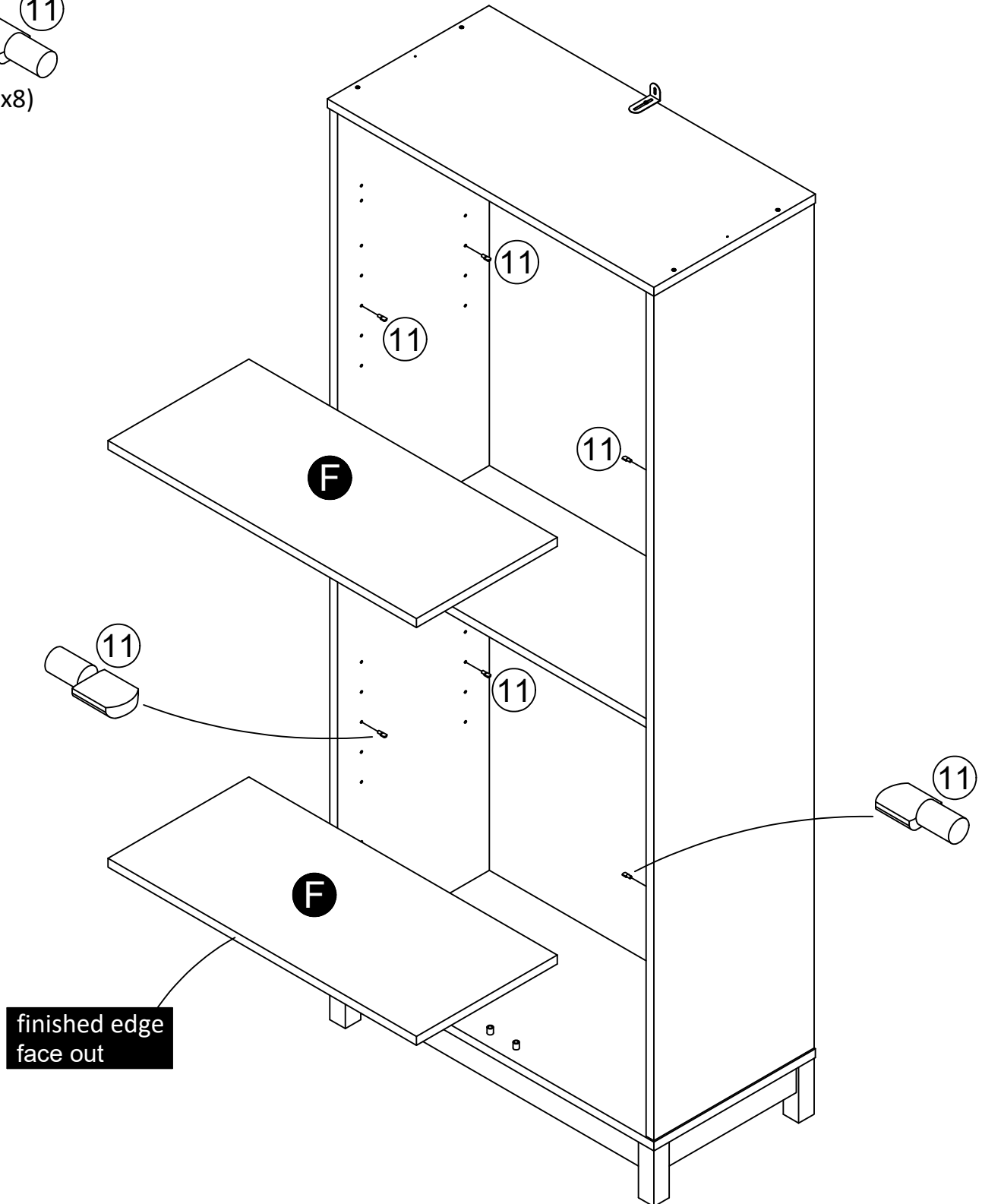
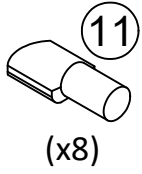

finished edge
face out

STEP 18

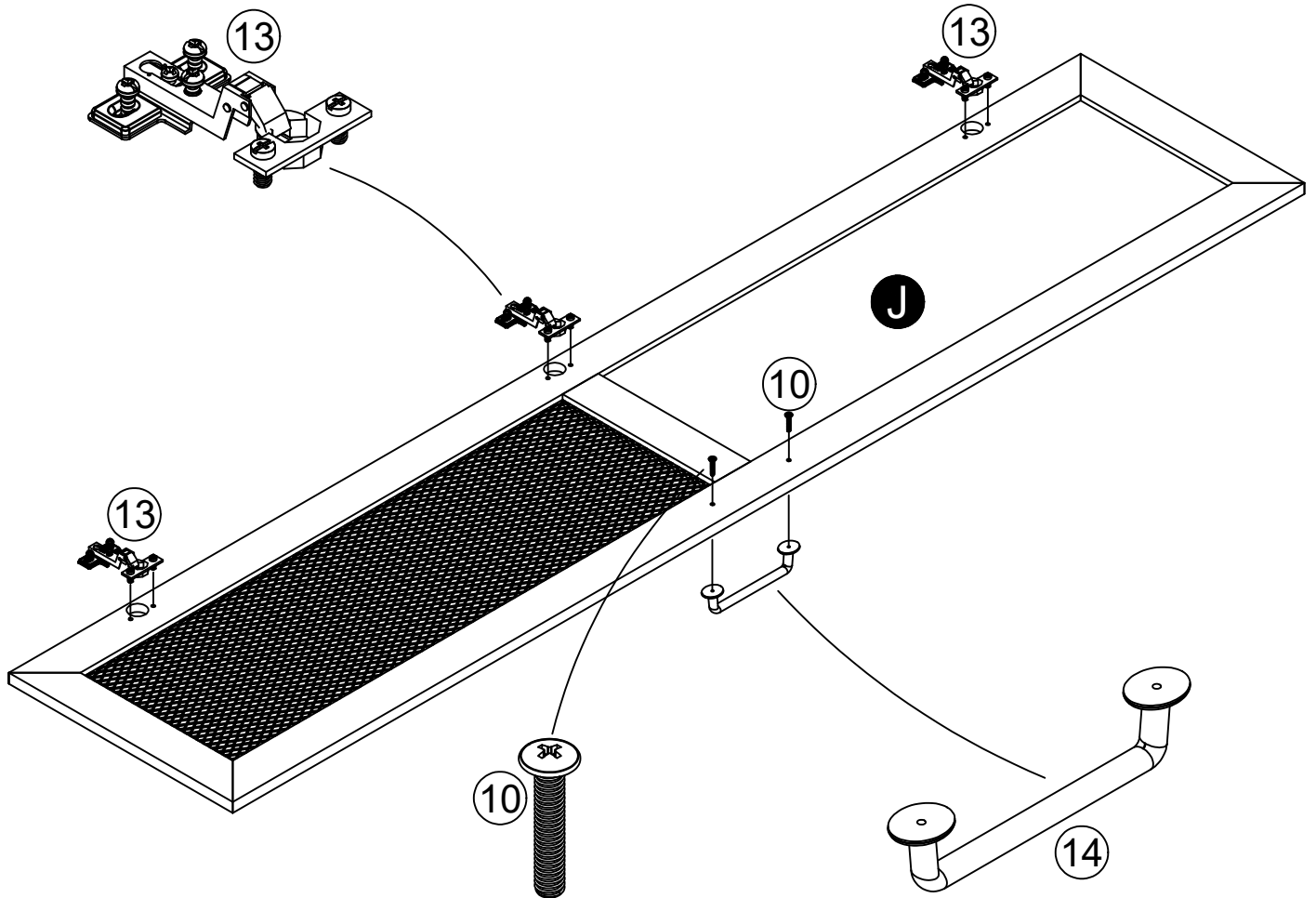
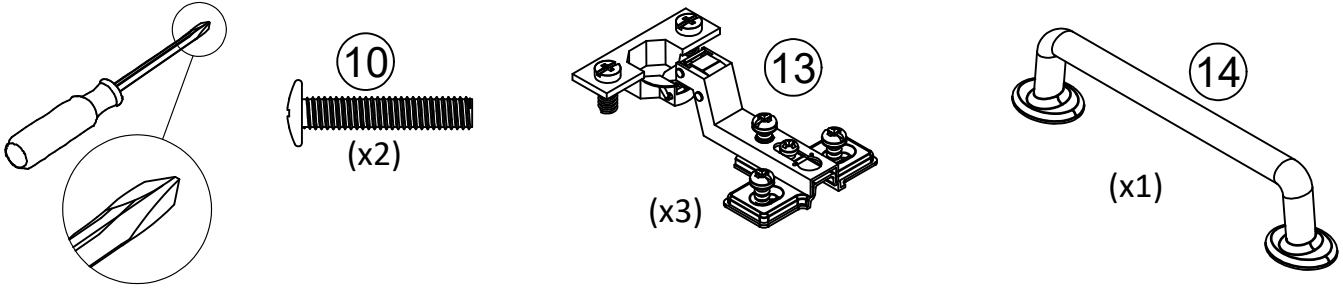

STEP 19

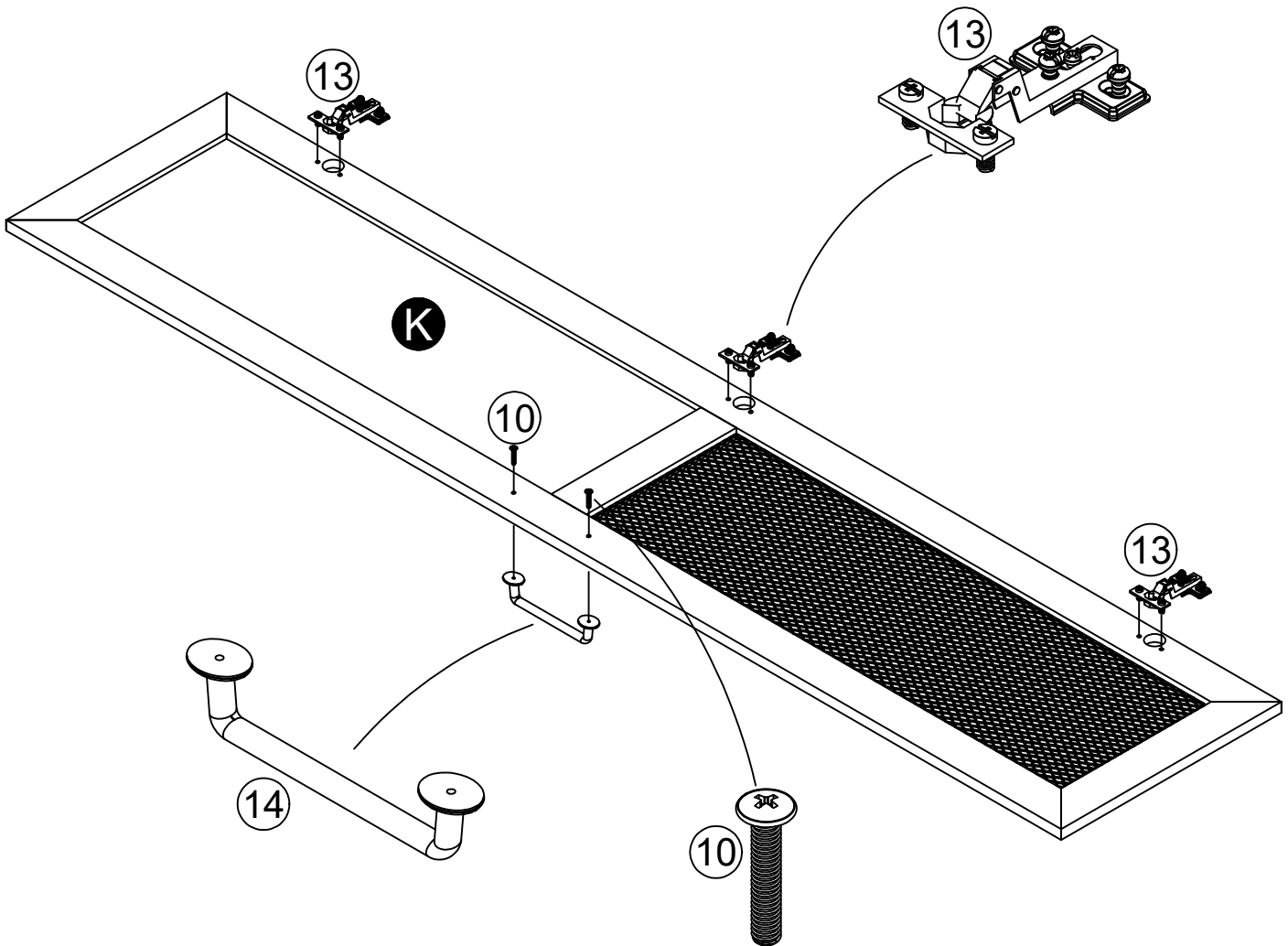
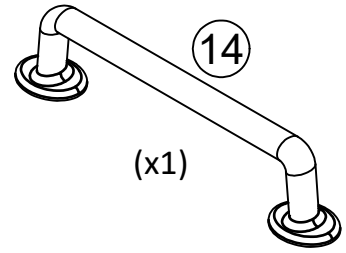
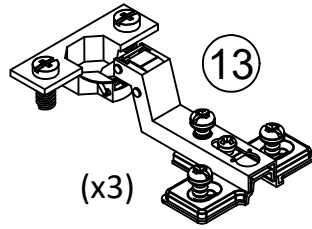
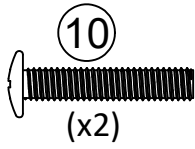
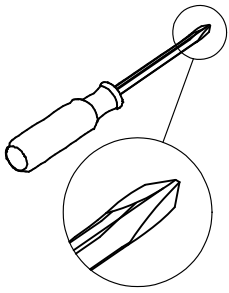

STEP 20

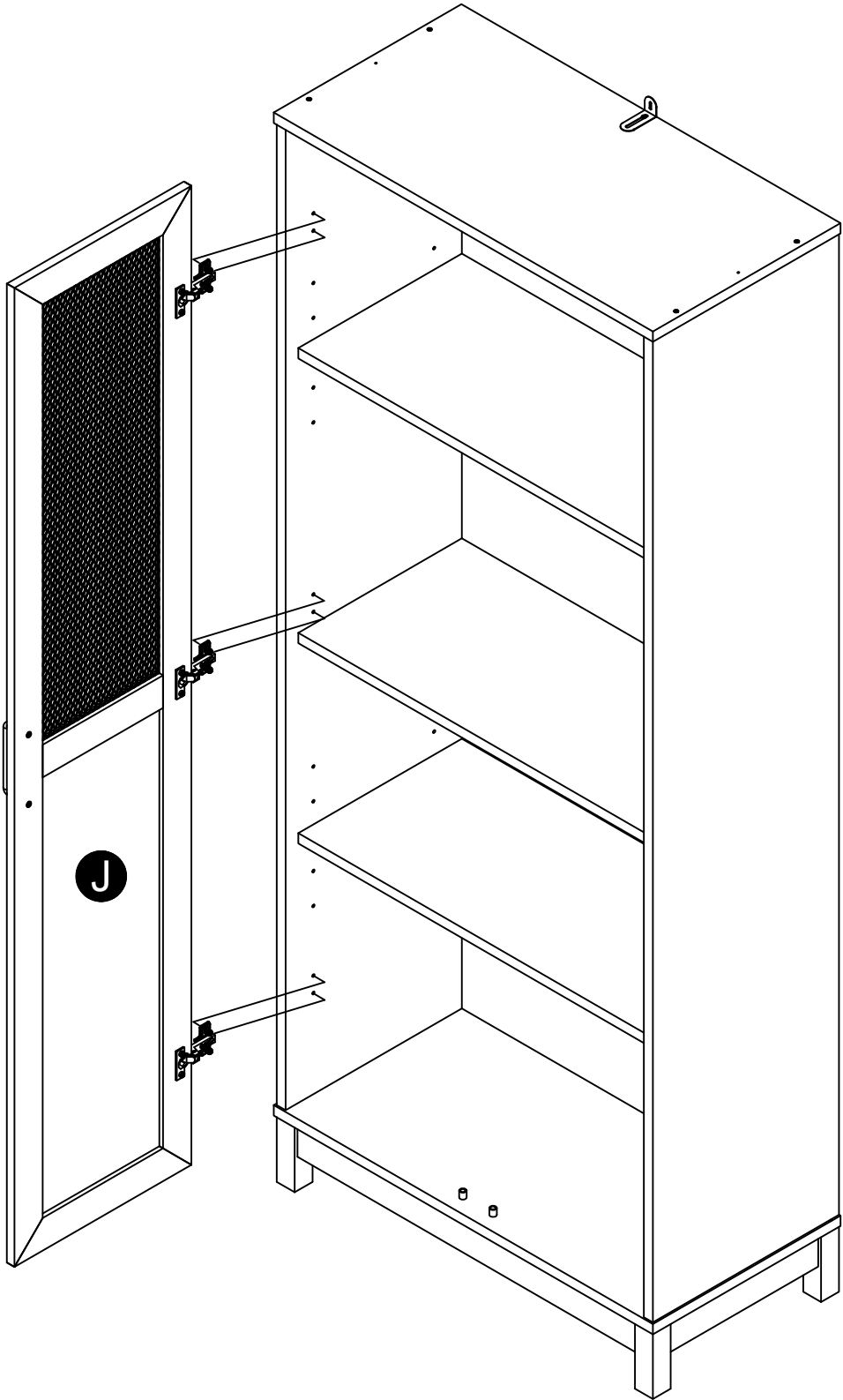
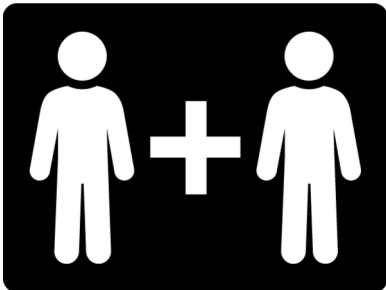
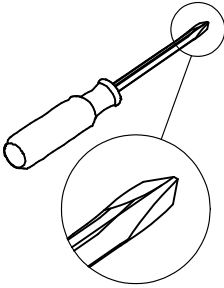

STEP 21

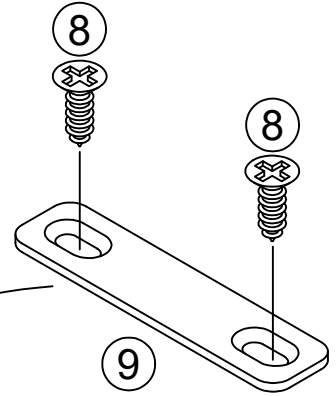
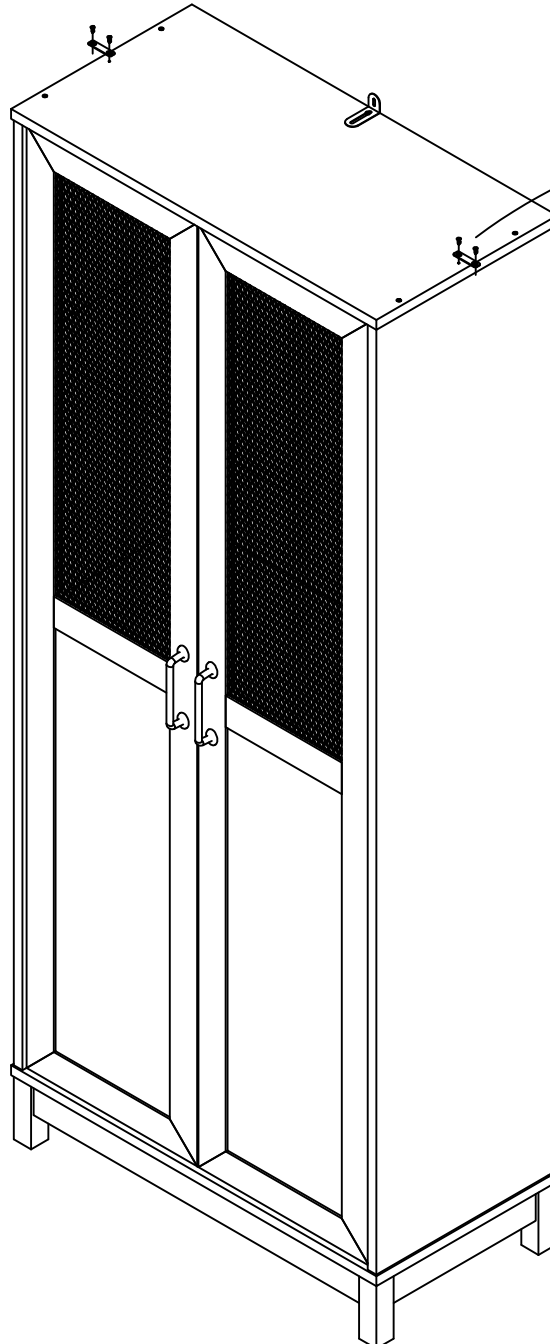
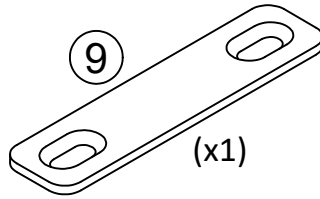
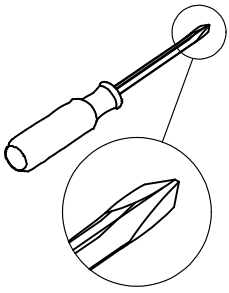

You can place two Cabinets side by side. Attach the two Cabinets together using the Straight Bracket (9).

STEP 22

Door Adjustment

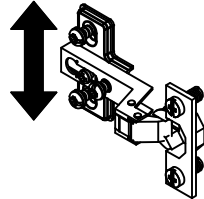
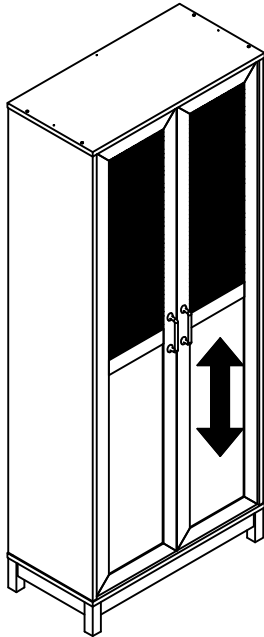
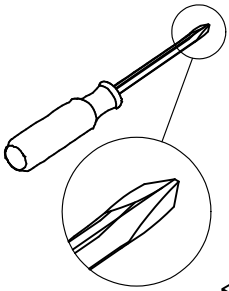

To adjust the vertical height:
Loosen the screws "A" on both hinges. They are usually in slotted holes which allows you to adjust up or down by a few mm. Then tighten back up.

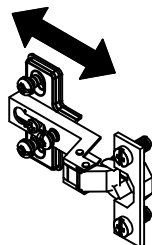
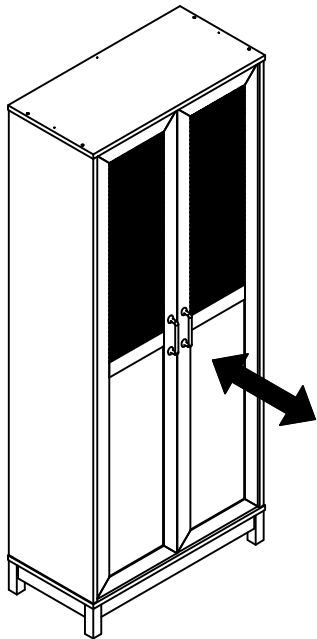
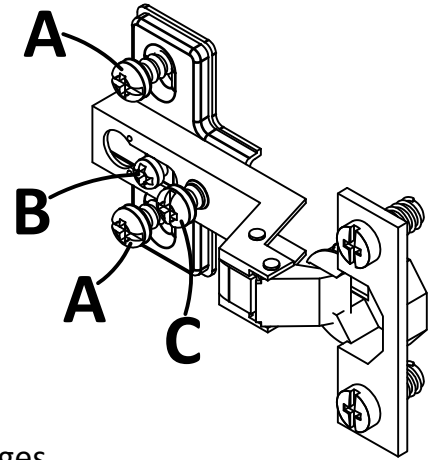

To adjust the depth:
Loosen the screw "B" and adjust door.

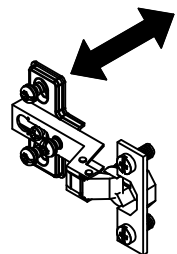
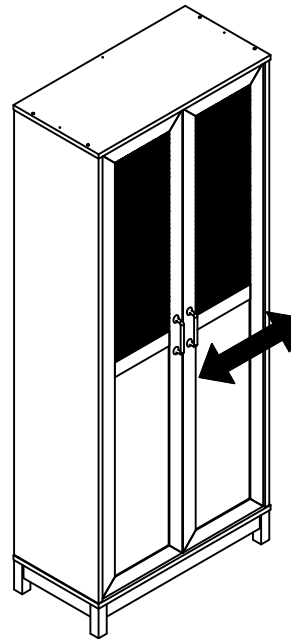

To adjust side to side:
Loosen the screw "C" on BOTH hinges and tighten "B" moves door outward. Loosen "B" and tighten "C" moves doors inward.

Maximum Loads

This unit has been designed to support the maximum loads shown. Exceeding these load limits could cause sagging, instability, product collapse, and/or serious injury.

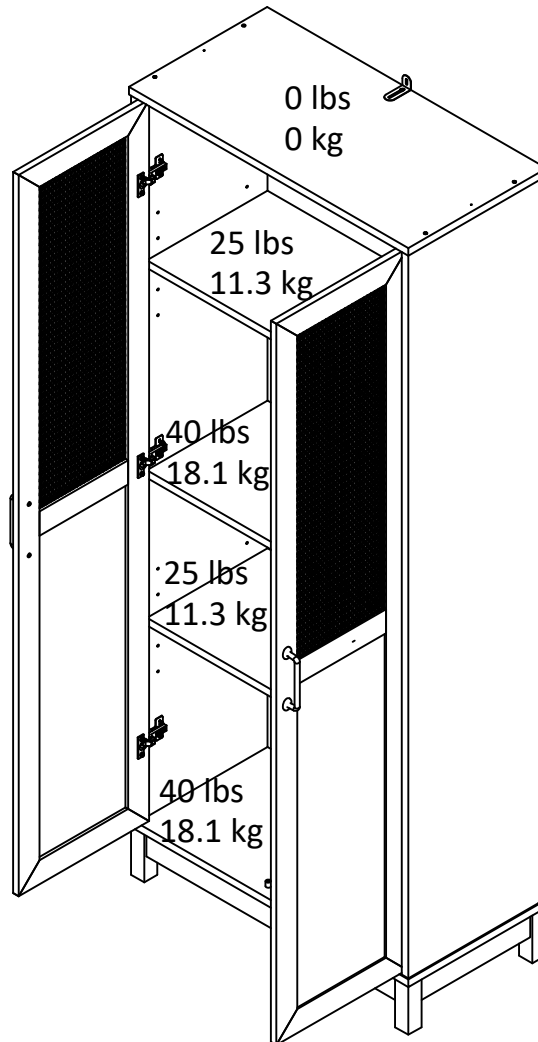

Warning: Risk of injury to persons - do not place a television on this furniture. This furniture is not approved for use with a television.

Certificate of Conformity

1. This certificate applies to the Dorel Home Furnishings, Inc. product identified by this instruction manual.
2. This certificate applies to compliance of this product with the CPSC Ban on Lead-Containing Paint (16 CFR 1303).
3. This product is distributed by: Dorel Home Furnishings, Inc.
410 East First Street South
Wright City, MO 63390
636-745-3351
4. Site of Manufacture: Tiffin OH
5. See front page of instruction manual for date of manufacture.

Register your product to receive the following:



- * New trend details - sneak peek on what's new
- * Surveys - have a voice within our community
- * Exclusive deals and discount codes
- * Quick and easy replacement part service

To register your product, visit ameriwoodhome.com

5 Star Rating



Visit your local retailer's website, rate your purchased product and leave us some feedback!

We would like to extend a big "Thank You" to all of our customers for taking the time to assemble this Ameriwood Home product, and to give us your valuable feedback.

*Thank
You!*

Cubierta Delantera

Este libro de instrucciones contiene información **IMPORTANTE** de seguridad. Por favor lea y manténgalo para referencia en el futuro.

No Regrese este producto! Comuníquese con nuestro amigoso equipo de servicio al cliente para obtener ayuda.

Llámenos al: 1-800-489-3351 (Gratis) Lunes - Viernes 9am - 5pm CST

Visitar: www.ameriwoodhome.com

PRECAUCION

Este mueble puede volcarse y causar graves heridas y/o muerte.

Anclar el mueble a un poste de madera en la pared (si esto se requiere).

No Permita que los niños monten el mueble.

Mantenga los artículos más pesados en los cajones de abajo.

Consejos Útiles (página 2)

- Abra su artículo en el área donde usted planea utilizarlo para evitar levantar y moverlo menos
- Identificar, ordenar y contar las piezas antes de intentar ensamblar
- Las clavijas de compresión se golpean con un martillo
- Las diapositivas están marcadas con una R (derecha) y L (izquierda) para la colocación correcta
- Asegúrese de que siempre este el punto localizado en la parte superior de bloqueador de leva este volteado hacia borde exterior
- Utilizar todos los clavos para el panel de atrás y distribuirlos por igual
- El panel de atrás debe utilizarse para asegurarse de que la unidad quede fija y firme
- No use químicas fuertes ni limpiadores abrasivos en este artículo
- Nunca empuje, tire ni arrastre los muebles

Antes de Que Empieces (página 3)

- Lea cuidadosamente cada paso y siga el orden correcto
- Separar y contar todas sus piezas y hardware
- Dése suficiente espacio para el proceso de ensamble
- Tenga las siguientes herramientas: destornillador de cabeza plana, #2 cabeza Phillips
Destornillador y martillo
- Precaución: Si usa un taladro electrónico o un destornillador eléctrico para atornillar, por favor asegúrese que deje de atornillar cuando el tornillo este apretado. Fallar hacer esto puede causar barrer el tornillo.

Sistema de fijar el bloqueo de leva (página 3)

Este sistema de fijar el bloqueo de leva sera usado en todo el proceso ensamble.

Página 14

¡IMPORTANTE! EL PANEL TRASERO ES UNA PARTE ESTRUCTURAL DE ESTA UNIDAD Y DEBE INSTALARSE ADECUADAMENTE.

Despliega el panel posterior. Con la superficie terminada hacia arriba, deslice el panel posterior en la ranura en los paneles izquierdo y derecho (A y B) que se encuentra en la ranura en la parte superior (C). Tenga en cuenta que el panel posterior estará sobre los soportes.

Página 15

Nota:

El borde inferior del panel posterior se fijará en la ranura de la parte inferior.

Página 18 / 19 / 20

Los bordes superiores de ambas partes estarán al ras.

Página 21

Gire el tornillo en el sentido de las agujas del reloj para sujetar las piezas juntas

Página 22

Para paredes de mampostería, hormigón u otros materiales:

Consulte en su ferretería local sobre anclajes adecuados para fijar el soporte de manera segura.

IMPORTANTE: ESTA UNIDAD DEBE FIJARSE EN LA PARED PARA EVITAR VUELCOS. SIGA ESTAS INSTRUCCIONES PARA INSTALAR EL SOPORTE ANTIVUELCO PROVISTO JUNTO A ESTE PRODUCTO.

ADVERTENCIA

En caso de volcarse el mueble, pueden ocurrir lesiones graves o fatales por aplastamiento.

Para evitar vuelcos:

- * Instale la cinta antivuelco provista.
- * Coloque los elementos más pesados en los cajones inferiores.
- * A menos que este producto haya sido diseñado específicamente para ello, no coloque televisores u otros objetos pesados sobre el mismo.
- * Nunca permita que los niños se suban o se cuelguen de los cajones, la puerta o los estantes.
- * Nunca abra más de un cajón a la vez.

El uso de las cintas antivuelco puede únicamente disminuir, mas no eliminar, el riesgo de vuelcos.

OPCIÓN 1: Fijación a un montante de pared (método de preferencia)

Utilice un detector de vigas para localizar un montante en la pared. Coloque la unidad contra la pared y alinee el soporte en ese lugar. Para atornillar más fácilmente, puede hacer un agujero piloto de 1/8" (3 mm) de diámetro con un taladro a través del soporte y sobre el montante de la pared. Atornille el soporte al montante.

OPCIÓN 2: Fijación a un panel de yeso

Ubique la unidad contra la pared en el sitio que desee y haga una marca en la pared a través del soporte. Corra la unidad a un lado. Con un taladro, haga un agujero de 3/16" (5 mm) de diámetro sobre el panel. Introduzca el anclaje de pared en el agujero hasta que quede al ras. Ubique la unidad en su lugar y atornille el soporte en el anclaje.

Página 28

Puede ubicar un gabinete junto a otro. Acople los dos gabinetes mediante el soporte recto (9).

Página 29

REGULACIÓN DE LA PUERTA

Para regular la altura vertical:

Afloje los tornillos "A" de ambas bisagras. Por lo general, se hallan en agujeros ranurados que le permiten regular unos milímetros hacia arriba o abajo. Luego vuelva a ajustar.

Para regular la profundidad:

Afloje el tornillo "B" y regule la puerta.

Para regular lateralmente:

Afloje el tornillo "C" de AMBAS bisagras y ajuste el "B" para mover la puerta hacia fuera. Afloje el "B" y ajuste el "C" para mover la puerta hacia dentro.

Página 30

CARGA MAXIMA

Esta unidad ha sido diseñada para soportar las cargas máximas indicadas. Exceder estos límites podría provocar el hundimiento, inestabilidad o desplome del producto y lesiones graves.

Advertencia: Riesgo de lesiones para personas. No coloque un televisor encima de este mueble. No se aprueba el uso de este mueble para apoyar un televisor.

Página 31

Registre su producto para recibir lo siguiente:

- * Detalles de nuevas tendencias - Vistazo a lo nuevo
- * Encuestas - aloc su voz entre su comunidad
- * Códigos de ofertas y descuentos exclusivos
- * Fácil y rápido servicio de partes de remplace

Para registrar su producto, visite ameriwoodhome.com

Clasificación de 5 estrellas

Visite el sitio web de su tienda local, califique su comprado y denos sus comentarios!

Nos gustaría enviar un gran "Agradecimiento" a todos nuestros clientes por tomarse el tiempo de ensamblar este producto de Ameriwood Home, y por darnos sus valiosos comentarios.

Gracias

Couverture Avant

CE LIVRET D'INSTRUCTION CONTIENT DES INFORMATIONS **IMPORTANTES** SUR LA SÉCURITÉ. VEUILLEZ LIRE ET GARDER POUR UNE RÉFÉRENCE FUTURE

Ne retournez pas ce produit! Contactez notre équipe de service à la clientèle amicale d'abord pour obtenir de l'aide.

Appelez-nous: 1-800-489-3351 (sans frais) du Lundi au Vendredi de 9h à 17h Heure Centrale

Visitez: www.ameriwoodhome.com

ATTENTION

Le meuble peut basculer et causer des blessures graves ou la mort.

Ancrer le meuble à une planche murale dans le mur (si indiqué).

Ne laissez pas les enfants grimper sur le meuble.

Placez les articles lourds sur les étagères ou dans les tiroirs inférieurs.

Astuces Utiles (page 2)

-Ouvrez votre article dans la zone que vous prévoyez de le garder pour moins de levage lourd

-Identifier, trier et compter les pièces avant d'essayer d'assembler

-Les goujons de compression sont taraudés avec un Marteau

-Les glissières sont marquées d'un R (droit) et d'un L (gauche) pour un bon placement

-Assurez-vous toujours de faire face la pointe situé sur le haut de la Serrure de Came vers le bord extérieur

-Utiliser tous les clous fournis pour le panneau arrière et les répartir également

-Le panneau arrière doit être utilisé pour vous assurer que votre appareil est robuste

-N'utilisez pas de produits chimiques agressifs ou de nettoyeurs abrasifs sur cet appareil

-Ne jamais pousser, tirer, ou faire glisser votre meuble

Avant de Commencer (page 3)

-Lisez attentivement chaque étape et suivez le bon ordre

-Séparez et comptez toutes vos pièces et matériaux

-Donnez-vous suffisamment de place pour l'assemblage

-Avoir les outils suivants: tournevis à tête plate, #2 tournevis Phillips, et Marteau

-Attention: Si vous utilisez une perceuse électrique ou un tournevis électrique pour visser, veillez à ralentir et arrêter lorsque la vis est bien serrée. Le non-respect de cette consigne peut endommager la vis.

Système de Fixation de Came (page 3)

Ce Système de Fixation de Came sera utilisé tout au long de l'assemblage

Page 14

IMPORTANT! LE PANNEAU ARRIÈRE EST UN ÉLÉMENT STRUCTUREL DU MEUBLE ET DOIT ÊTRE INSTALLÉ CORRECTEMENT.

Dépliez le panneau arrière. Avec la surface finie tournée vers le haut, faites glisser le panneau arrière dans la rainure des panneaux gauche et droit (A & B) assis dans la rainure dans le haut (C). Notez que le panneau arrière sera au-dessus des supports.

Page 15

Remarque :

Le bord inférieur du panneau arrière se fixera dans la rainure du bas.

Page 18 / 19 / 20

Les bords supérieurs des deux parties seront affleurants.

Page 21

Tournez la vis dans le sens des aiguilles d'une montre pour serrer les pièces ensemble

Page 22

Pour la maçonnerie, le béton ou d'autres matériaux muraux :

Consultez votre quincaillerie locale pour obtenir les ancrages appropriés afin de fixer solidement le support de sécurité.

IMPORTANT : CE MEUBLE DOIT ÊTRE FIXÉ AU MUR POUR ÉVITER QU'IL NE BASCULE. SUIVEZ CES INSTRUCTIONS POUR INSTALLER LE SUPPORT DE SÉCURITÉ ANTI-BASCULEMENT FOURNI AVEC CE PRODUIT.

AVERTISSEMENT

Le basculement d'un meuble peut entraîner des blessures graves ou mortelles par écrasement.

Pour éviter le basculement :

- * Installer un dispositif de retenue en cas de basculement
- * Placer les objets les plus lourds dans les tiroirs les plus bas.
- * Ne pas poser de téléviseur ou d'autres objets lourds sur le dessus du meuble, à moins qu'il n'ait été spécifiquement conçu à cet effet.
- * Ne jamais permettre aux enfants de grimper ou de s'accrocher aux tiroirs, aux portes ou aux étagères.
- * Ne jamais ouvrir plus d'un tiroir à la fois.

L'utilisation de dispositifs anti-basculement ne peut que réduire, mais pas éliminer, le risque de basculement.

OPTION 1 : Fixation dans un montant mural (méthode préférée)

À l'aide d'un détecteur de montants, repérez un montant dans le mur. Placez votre meuble contre le mur, en alignant l'étrier de sécurité à cet endroit. Pour faciliter l'enfoncement de la vis, vous pouvez percer un avant-trou de 1/8" de diamètre (3 mm) à travers le support de sécurité dans le montant. Enfoncez la vis à travers le support de sécurité dans le montant du mur.

OPTION 2 : Fixation dans la cloison sèche

Placez votre meuble à l'endroit désiré contre un mur et marquez le mur à travers le support de sécurité, puis mettez votre meuble à l'écart. Percez un trou de 3/16" de diamètre (5 mm) dans le panneau mural. Tapez la cheville dans le trou jusqu'à ce qu'elle soit à fleur. Mettez votre meuble en place et fixez le support mural à l'ancrage mural à l'aide de la vis.

Page 28

Vous pouvez placer deux armoires côte à côte. Fixez les deux armoires ensemble à l'aide du support droit (9).

Page 29

RÉGLAGE DE LA PORTE

Pour ajuster la hauteur verticale :

Desserrez les vis « A » des deux charnières. Elles se trouvent généralement dans des trous oblongs, ce qui vous permet de les ajuster de quelques millimètres vers le haut ou vers le bas. Resserrez ensuite les vis.

Pour ajuster la profondeur :

Desserrer la vis « B » et ajuster la porte.

Pour régler d'un côté à l'autre :

Desserrez la vis « C » sur les DEUX charnières et serrez « B » pour déplacer la porte vers l'extérieur. Desserrer la vis « B » et serrez la vis « C » pour déplacer la porte vers l'intérieur.

Page 30

CHARGES MAXIMALES

Cet appareil a été conçu pour supporter les charges maximales indiquées. Le dépassement de ces limites de charge peut entraîner un affaissement, une instabilité, un effondrement du produit et/ou des blessures graves.

Avertissement : Risque de blessure pour les personnes -- ne placez pas de téléviseur sur ce meuble. Ce meuble n'est pas homologué pour être utilisé avec un téléviseur.

Page 31

Enregistrez votre produit pour recevoir les éléments suivantes:

- * Détails sur les nouvelles tendances - un aperçu sur les nouveautés
- * Sondages - avoir une voix au sein de notre communauté
- * Offres exclusives et codes promo
- * Service de pièces de rechange rapide et facile

Pour enregistrer votre produit, visitez ameriwoodhome.com

5 Étoiles

Visitez le site Web de votre détaillant local, évaluez votre produit acheté et laissez-nous quelques commentaires !

Nous tenons à offrir un grand "Merci" à tous nos clients pour avoir pris le temps d'assembler ce produit "Ameriwood Home", et de nous donner vos commentaires précieux.

Merci